

<THESE INSTRUCTIONS MUST BE GIVEN TO THE END USER>



B&W Trailer Hitches
 1216 Hawaii Rd / PO Box 186
 Humboldt, KS 66748
 P:800.248.6564
 F:620.869.9031

Call or Email us for
 Installation Support
 hitches@turnoverball.com
 www.bwtrailerhitches.com

Turnoverball® Gooseneck Hitch Installation Instructions

Model 1313

2003 - 2009 Dodge 3/4 & 1 Ton Long & Short Bed Gas or Diesel Trucks

2010 - 2012 RAM 3/4 & 1 Ton Long & Short Bed Diesel Trucks

2013 RAM 3/4 Ton Long and Short Bed Diesel Trucks

Excludes Mega-Cab Trucks

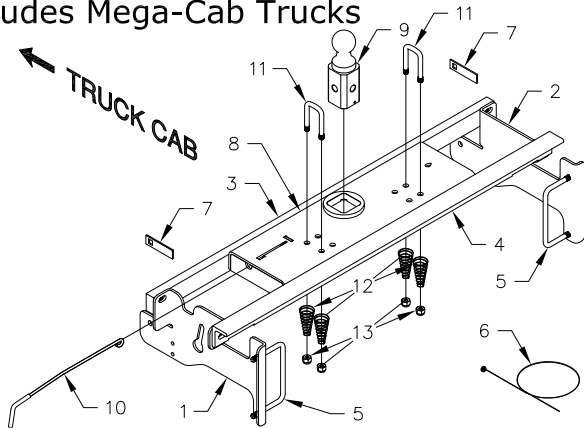

Center Box (GNRC900)		
ITEM	DESCRIPTION	QTY
8	Center Section	1
9	2-5/16" Ball	1
10	Latch Pin Handle	1
Safety Chain Bolt Bag		
11	1/2" U-Bolt	2
12	Conical Springs	4
13	1/2" Lock Nut	4
	5/16" X 3/4" Carriage Bolt	1
	5/16" X 3/4" Cap Screw	1
	5/16" Flange Nut	1

Mounting Kit Box (GNRM1313)		
ITEM	DESCRIPTION	QTY
1	Driver Side Sideplate	1
2	Passenger Side Sideplate	1
3	Front Crossmember	1
4	Rear Crossmember	1
5	1/2" X 6-1/4" X 4" U-Bolt	2
6	1/2" X 48" Fishwire	2
Mounting Kit Bolt Bag		
7	Locking Strap	2
	1/2" X 2" Carriage Bolt	2
	1/2" X 1-1/2" Cap Screw	11
	1/2" Finish Nut	11
	1/2" Lock Washer	17
	1/2" Flat Washer	11

ATTENTION: If you intend to use an 18K Companion 5th Wheel RV Hitch model 3000 in a **2013 or newer RAM** truck, please call us at 800-248-6564 for a kit that fills voids in the truck bed rib pattern. Using the model 3000 Companion on a **2013 or newer RAM** without the supplemental kit could result in damage. RV Models 3400 and 3500 do not need a supplemental kit.

WARNING

Failure to comply with the safety information in these instructions could result in serious injury or death.

- Read all installation and operating instructions along with all labels before installing or using this product.
- Adding components such as a Turnoverball hitch to the chassis of any vehicle can be hazardous. There is potential for unexpected combustion of fuel, electric shock, burns, shifting or falling of unstable vehicle, damage to vehicle, injury from tool usage and many other hazards. This installation must be completed by someone who is aware of the hazards involved. This person must be knowledgeable of proper safety procedures for a vehicle modification of this nature, and for usage of the equipment required to perform the installation.
- Without proper knowledge, towing can be a dangerous activity. Understand all the risks involved with towing before proceeding. For information on towing safety, see **"The Trailer Handbook: A Guide to Understanding Trailer and Towing Safety"** from the National Association of Trailer Manufacturers, www.NATM.com and your trailer manufacturer's owner's manual.
- Do not exceed tow or tongue rating of coupler, tow or tongue rating of hitch, or tow or weight ratings of truck or trailer. See vehicle and trailer manufacturer information for ratings. Exceeding these ratings may cause damage to towing components or loss of attachment between the trailer and truck.
- Do not modify this product in any manner. Doing so could alter its integrity and lead to a loss of attachment between the trailer and the tow vehicle.
- Additional caution must be used when towing a wedge car trailer. Towing stability greatly depends on keeping the center of gravity as low as possible. Load heavy cars over the axles. Never tow with a single car on the front of the trailer. When towing a wedge car trailer, never exceed speeds that are reasonable for the roadway conditions (e.g. turns, going around a curve, etc.). Failure to account for proper trailer center of gravity and speeds that are reasonable for the roadway conditions may cause damage to the truck, trailer, towing components, and loss of attachment between the truck and trailer.
- This product was designed to fit vehicles in their original, "as manufactured" condition. Compatibility with vehicles having replacement parts, or other modifications is not guaranteed. Inspect vehicle for modifications before installation of this product.
- The Turnoverball hitch comes equipped with a 2-5/16" ball. Trailers towed with the ball provided must have a 2-5/16" coupler. Towing with a larger coupler could cause loss of attachment between the trailer and the tow vehicle.
- A visual inspection of the hitch should be performed before each time you tow. Regularly check that all pinned connections are secure, and that all bolted connections are at the correct torque specification. Check for cracks or damage to the hitch. Do not tow with the hitch if cracks or damage outside of normal wear is found. Towing with a hitch that has cracks or damage could result in damage to the tow vehicle, trailer, towing components or loss of attachment between the tow vehicle and trailer.

PREPARING TO INSTALL

Installation of the Turnoverball hitch requires several common tools and a few specialized tools. Below is a listing of equipment used during a typical installation.

- Impact wrench or ratchet with $\frac{9}{16}$ " & $\frac{3}{4}$ " sockets
- $\frac{3}{4}$ " and $\frac{9}{16}$ " box end wrench
- aviation snips for cutting sheet metal
- 4" hole saw
- flashlight
- drill with $\frac{1}{2}$ " bit
- eye protection
- torque wrench
- adjustable wrench
- lifting device
- tape measure
- ear protection

1. **Determine cab clearance.** The Turnoverball hitch is designed so that the ball can be inverted and stored below the surface of the truck bed while not in use. The ball location is determined by this design feature and the truck geometry. Measure the trailers to be towed with this hitch to be sure that the location of the 2-5/16" ball listed in step 7 will provide ample turning clearance between the nose of the trailers and the cab of the truck.

WARNING: Cab clearance on short bed trucks is very limited when towing certain trailers. Failure to ensure that there will be adequate clearance, may result in significant property damage, or serious injury.

2. **Remove the spare tire (optional).** Following the vehicle manufacturer's instructions, remove the spare tire. This will provide easier access to the area where the hitch will be installed.

3. **Position the vehicle.** Installation of the hitch requires the installer to be under the truck bed in the area of the rear axle. Lifting the vehicle makes this area more accessible to the installer, and improves the installation process.

Lift vehicle using only equipment designed for lifting and positioning vehicles for service. Failure to do so may result in property damage, serious injury, or death.

4. **Prepare a lifting device (optional).** The purpose of the device is to safely hold the hitch in position during part of the installation. See figure A1 for an example. A simple mechanical lifting device is available for purchase from B&W.

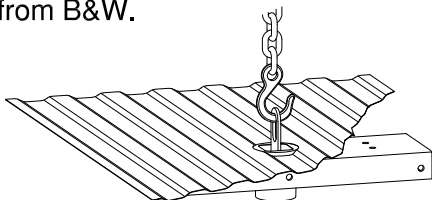

Figure A1

5. **Remove or modify fender liners as needed.** Some vehicles are equipped with various designs of plastic liners inside the rear wheel wells. If the liners prevent access to the opening between the bed and the frame, just over the axle, they may need to be removed or cut to install hitch cross members and handle.

6. **Mark the 4" hole location.** Using a tape measure hooked over the rear edge of the bed (at tailgate end), measure the location for the hole as shown in figure A2. Next, locate the center of the bed by measuring the distance between the wheel wells and dividing by two. The center of the hole will be at the intersection of the center of the bed and the first distance measured.

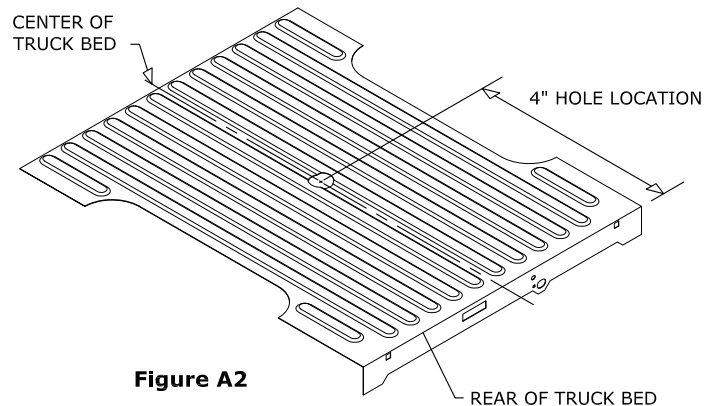

Figure A2

8' LONG BED - 47 $\frac{1}{2}$ "

SHORT BED (BED LESS THAN 8' LONG) - 45 $\frac{1}{2}$ "

IMPORTANT: The hitch is designed to install only at the described location. Failure to place the 4" hole precisely may result in added difficulty during installation or property damage.

IMPORTANT: If the bed is equipped with a plastic bed liner, the hole may be cut through both the liner and the bed. However, the center of truck bed may be more difficult to locate, and the mark may be harder to hit if the liner slides or moves. Failure to cut the hole in the correct location may adversely affect the install and may result in property damage.

IMPORTANT: If your truck has a spray-in bed liner you will need to take this into account when you are measuring, and add the thickness of the applied liner that has been sprayed over the end of the bed.

7. **Cut the 4" diameter hole.** Cut the hole in the marked location using a 4" hole saw or by marking out the 4" hole and using a saber saw equipped with a metal cutting blade. Remove any burrs created while cutting hole.

8. **Modify bed flange.** Cut a notch in the bed flange just above the frame in the passenger side rear wheel. Locate the 7/16" hole in this flange above the axle and enlarge the hole by removing the metal below the hole so that a notch is created, See figure A3 & A4. This will allow the rear cross member to be installed.

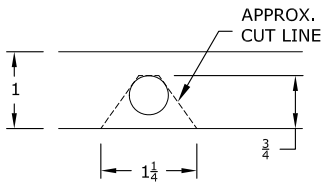

Figure A3

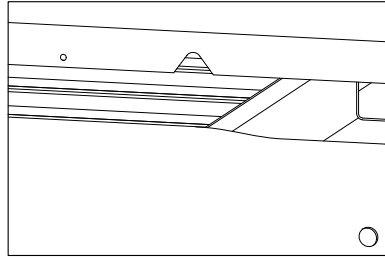

Figure A4

INSTALL CROSS MEMBERS AND CENTER SECTION

- WARNING:** Most trucks have fuel lines, brake lines, electrical wires or other vehicle systems located along the frame rails or in the general area where B&W Turnoverball hitches install. Carefully examine the locations of these systems before installation. Make certain that these are not damaged during positioning hitch components, drilling holes, or tightening fasteners. Damage to these systems may result in property damage, serious injury, or death.

- WARNING:** Turnoverball hitch components are heavy and may be cumbersome to handle. Failure to use proper lifting techniques and caution when handling these items could result in serious injury.

1. **Place Cross Members.** Using the notch cut in the bed flange inside the passenger side rear wheel well, slide the cross member across the frame until it spans both frame rails, See figure B1. Rotate cross member so that the holes on the end of the cross member are closest to the floor of the bed. Push cross member forward against bed cross member, See figure B2. Using the notch for clearance install the rear cross member with the angle oriented so that the leg with the slotted holes is facing the front of the truck, See figure B3. Hold the rear cross member in an inverted V position, and push the angle across the frame. Slide the cross member toward the rear of the truck so that there is approximately 10 inches between both cross members. Then rotate the cross member so that the leg with the slotted holes is vertical, See figure B4.

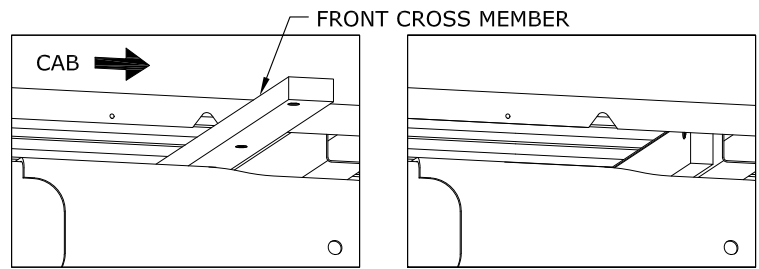

Figure B1

Figure B2

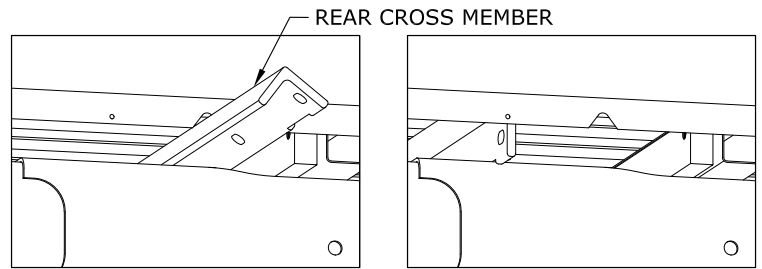

Figure B3

Figure B4

2. **Install Center Section.** Install the center section with the latch pin on the driver side. Raise the center section over the differential while sliding the center section over the exhaust and guiding the raised 4" circle on top of the center into the 4" hole in the truck bed floor, See figure B5. Move rear cross member forward against the center section. Place a 1/2" flat washer on a 1/2" X 1 1/2" hex cap screw. Insert the cap screw through the rear cross member and center section, securing it with a 1/2" lock washer, and a 1/2" finish nut. Thread a 1/2" X 1 1/2" hex cap screw with a 1/2" lock washer and a 1/2" flat washer into the front cross member from the inside of the center section, See figure B6. (Do not tighten hardware at this time)

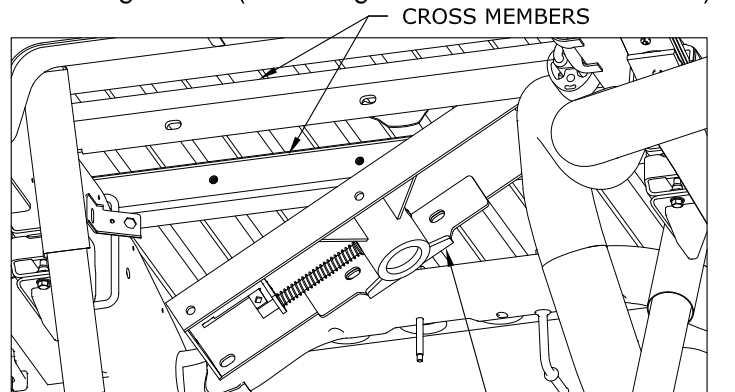

Figure B5: View under bed looking at area above axle.

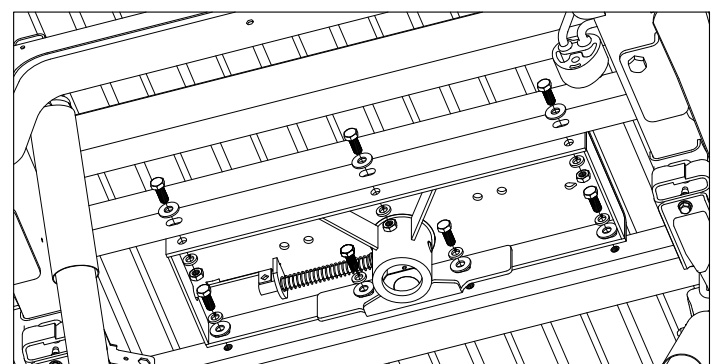

Figure B6: View under bed of hardware assembly.

INSTALL SIDE PLATES

- 1. Prepare to install sideplates.** Before installing the sideplates it is necessary to temporarily remove a brake cable bracket on the driver side of the frame, See figure C1. The M8 bolt will be needed to re-attach the bracket in a later step.
- 2. Fish carriage bolts through frame.** A fish wire will be required to install the 1/2" X 2" Carriage bolts which hold each sideplate in place. Start by locating the mounting hole in the side of the frame, shown below in figure C2. Feed the coiled end of the fish wire through the hole until it is visible in the 1-1/2" hole near the back of the frame as shown in figure C4. Attach a locking strap and the 1/2" X 2" carriage bolt to the fish wire as shown in figures C3 & C4. The locking strap should not be inserted into the bolt while passing through the frame. Once attached, carefully pull the fish wire back through the frame. Pull the carriage bolt out of the hole in the frame, ensure that the carriage bolt has been pulled all the way through the locking strap and the bolts rotation is restricted.
- 3. Install the sideplates.** Next, while the fish wire is still attached to the carriage bolt, thread the length of the fish wire through the mounting hole on the sideplate, see figure C5. Next attach the sideplate to the front and rear crossmembers using 1/2" hardware as shown in figure C6.

IMPORTANT: In some truck models there may be wiring in the area where the U-bolt will need to be installed. The U-bolt must be between any wires and the frame to prevent wiring damage. Un-attach any plastic wiring holders to clear the area where the U-bolt will install, you will need to make sure the wiring is held in place securely before finishing, this can be accomplished with a wire tie or in some cases simply replacing the wiring holder in the frame.

- 4. Move wire plug.** On some truck models a small wire plug will have to be moved in order to install the U-Bolt. Pull the wire bracket from the frame and cut one of the plastic ratchet fasteners as shown in figure C7. Once the U-bolt is installed plug the remaining plastic ratchet fastener into the hole where the cut ratchet fastener was in the original installation.
- 5. Install U-Bolt.** Install the U-bolts from inside the frame. Place the U-bolt against the frame staying under the wiring harness and brake line. While making certain that nothing is between the frame and U-bolt, raise the U-bolt until the top leg is level with the top of the frame rail. Then turn the legs toward the outside so that the U-bolt straddles the frame and the legs pass through the two holes in the sideplate. Attach the carriage bolt and U-bolt with 1/2" hardware, as shown in figure C8. (Do not tighten hardware at this time.)

- 6. Replace cable bracket.** If the brake cable bracket was removed at the beginning of the side plate installation, replace it onto the drivers side plate using the M8 bolt that was originally in the frame, See Figure C9.

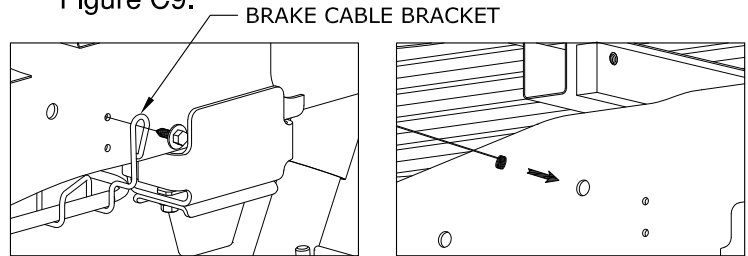

Figure C1: View from outside of Driver Side Frame.

Figure C2: View from outside of Driver Side Frame.

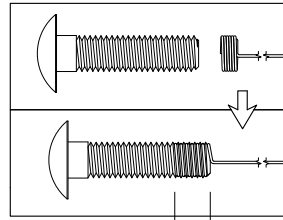

Figure C3: Fish wire diagram.

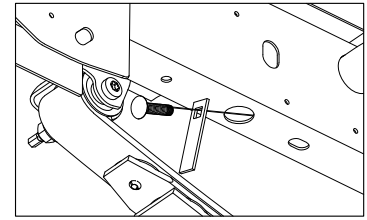

Figure C4: View looking up at rear of driver side frame

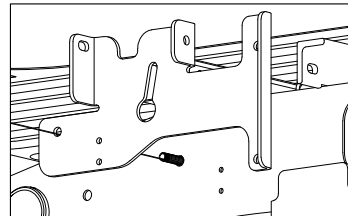

Figure C5: View from outside of Driver Side Frame.

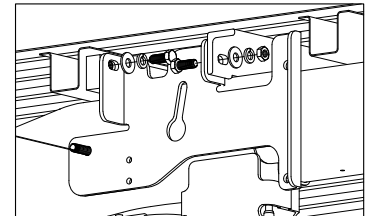

Figure C6: View from outside of Driver Side Frame.

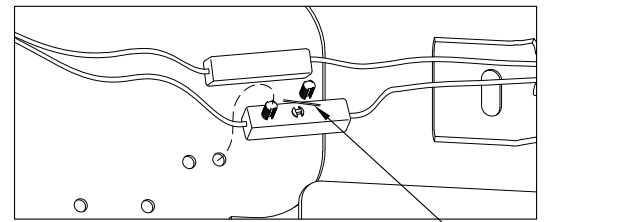

Figure C7: View looking at the inside of the Driver Side Frame.

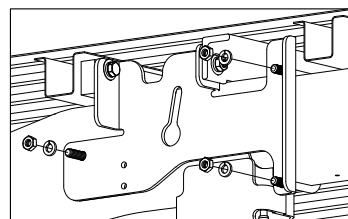

Figure C8: View from outside of Driver Side Frame.

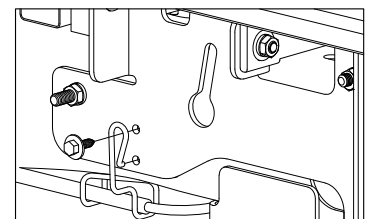

Figure C9: View from outside of Driver Side Frame.

SECURE HITCH

1. **Tighten center section bolts.** With the top surface of the center section firmly against the truck bed, tighten the bolts securing the two cross members to the center section.
2. **Square the hitch.** With a tape measure, check the distance between the Turnoverball hitch and the nearest bed crossmember. The distance between the hitch and the crossmember should be consistent on the passenger side and the driver side of the hitch, see figure D1. Adjust hitch until the hitch and the bed crossmember are the same from side to side.

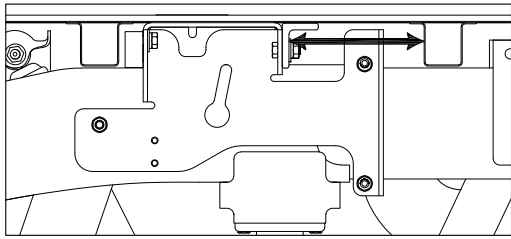

Figure D1: Driver side of truck frame inside the wheel well.

IMPORTANT: The hitch must be square in the truck. If the center section is not parallel with the axle, certain accessories to the Turnoverball hitch will not be square with the truck.

3. **Tighten side plate bolts.** Tighten the $\frac{1}{2}$ " bolts, securing the side plates to the frame. Then tighten the $\frac{1}{2}$ " bolts that attach the side plates to the cross members.
 4. **Torque all fasteners.** Torque the $\frac{1}{2}$ " bolts to 110 ft. lbs. and torque the U-bolts to 60 ft. lbs.
- ⚠ WARNING:** Failure to follow the bolt tightening sequence as listed above may result in the hitch components being misaligned which could affect the performance of the hitch, or result in property damage, or serious injury.
5. **Disengage lifting device.** If a lifting device was used to hold the center section in place during the installation, remove it at this time.

INSTALL LATCH PIN RELEASE HANDLE.

IMPORTANT: The latch pin will not function properly if handle is not installed correctly.

1. Install the latch pin release handle by inserting it through the slot in the end of the center section on the driver's side of the truck. Align the handle eyelet with the square hole in the latch pin so the handle is in line with the latch as shown in figure E1.
2. Secure the handle to the pin with the $\frac{5}{16}$ " X $\frac{3}{4}$ " carriage bolt and $\frac{5}{16}$ " locking flange, see figure E2. Note: The included $\frac{5}{16}$ " cap screw can replace the carriage bolt if wrench access on the "cab side" of the handle is limited. Tighten the nut until it is secure. Do not over-tighten and deform the handle eyelet.

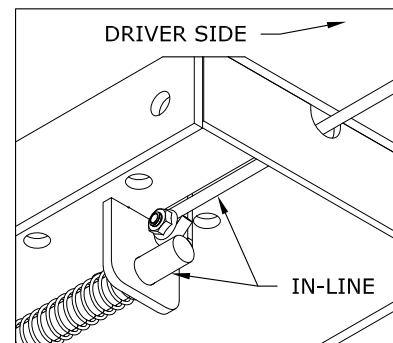

Figure E1: Center Section

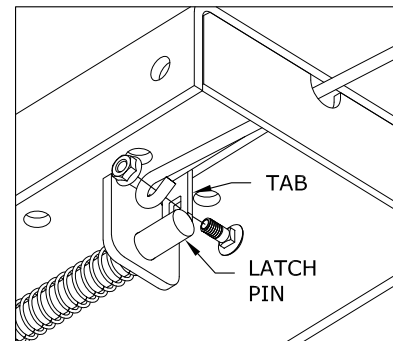

Figure E2: Handle Installation

INSTALL SAFETY CHAIN U-BOLTS

WARNING: This Turnoverball hitch is equipped with holes in the center section for mounting safety chain u-bolts. The hitch is designed so that the u-bolts will be in a low rib of the truck bed in order to reduce the amount of obstruction in the bed. The center section of the hitch may have more than one set of holes. One set of holes should match up with a low rib of the truck bed. Carefully examine the safety chain holes in the center section to determine which holes are under a low rib, see figure F1.

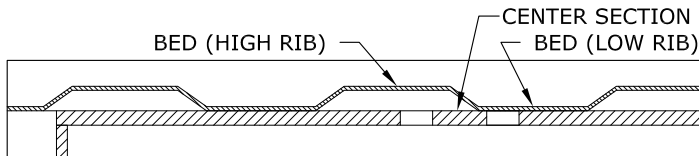

Figure F1: Cut away view of bed and center section

1. **Drill the holes.** From under the bed use a drill and a $\frac{1}{2}$ " drill bit to drill through the bed using the four holes that match up with a low rib in the truck as a guide. Remove any burrs created during the drilling process, see figure F2.

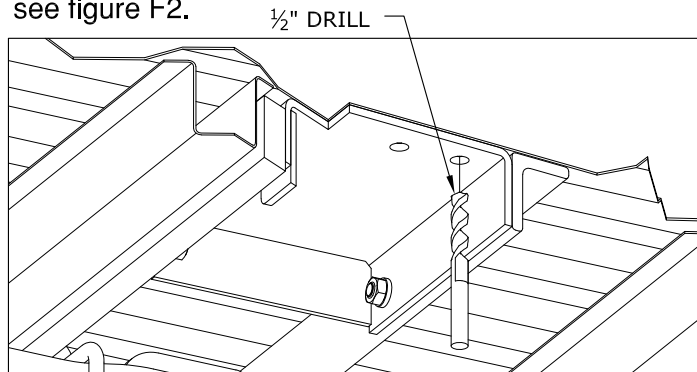

Figure F2: Cut away view from under the bed

2. **Install the U-bolts.** From the top side of the truck bed, drop a u-bolt in each set of holes.
3. **Add springs.** Place a conical spring over each leg of the u-bolts and secure with a $\frac{1}{2}$ " lock nut, see figure F3. Tighten the lock nut until the nut is flush with the end of the u-bolt.

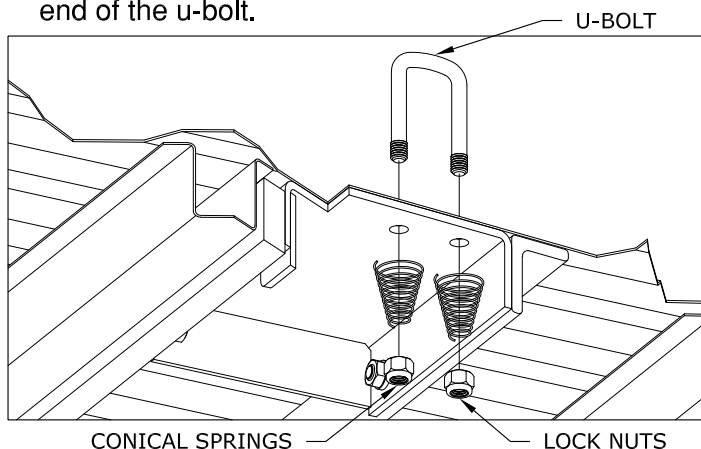

Figure F3: Cut away view from under the bed.

PREPARE FOR TOWING

1. **Replace spare tire.** If the spare tire was removed prior to installing the hitch, replace it at this time.
2. **Modify fender liner.** If a fender liner is present that restricts the movement of the handle, it is recommended that it be modified by cutting a relief slot or hole to allow the handle to move freely. If the liner was removed for installation, reinstall at this time.
3. **Retract the pin.** Pull the handle out all the way until it stops, then rotate it clockwise. The handle should stay in this position. The latch should only be put in this "open" position when inverting the $2\text{-}5/16$ " ball or installing a B&W towing accessory.

WARNING: Operating the tow vehicle while the latch is in the open position may allow the handle to come into contact with the rear tire. This may damage the tire or the handle and could lead to serious injury or death.

4. **Lubricate $2\text{-}5/16$ ball.** Apply a light coating of grease to the four corners on the square shank of the $2\text{-}5/16$ ball.

5. **Engage pin.** Rotate the handle counter clockwise until the handle retracts and engages the $2\text{-}5/16$ ball.

WARNING: When installed properly the latch pin will pass through the $2\text{-}5/16$ ball and fully engage through both walls of the hitch receiver. Failure of the pin to engage the ball and hitch properly could result in a loss of attachment between the trailer and the tow vehicle.

WARNING: Inverting the ball while hauling heavy loads may cause the ball to strike the truck's differential, drive line, or other components. Inspect the relationship between the ball and truck components to ensure the proper clearance. Failure to remove the ball when hauling heavy loads may result in property damage, injury or death. A cover to prevent debris from entering the socket while operating without the ball in place is available from B&W.

6. **Re-read front page.** Re-read all warnings on front page of these instructions. If you are not the end user, make sure that users of this product receive a copy of these instructions.