

# <THESE INSTRUCTIONS MUST BE GIVEN TO THE END USER>



## B&W Trailer Hitches

1216 Hawaii Rd / PO Box 186  
Humboldt, KS 66748  
P: 800.248.6564  
F: 620.869.9031

See Limited Lifetime Warranty at  
[bwtrailerhitches.com/warranty](http://bwtrailerhitches.com/warranty)

Call or Email us for  
Installation Support  
[hitches@turnoverball.com](mailto:hitches@turnoverball.com)  
[bwtrailerhitches.com](http://bwtrailerhitches.com)

## Turnoverball® Gooseneck Hitch Installation Instructions

To get the latest truck fit information, go to our website:  
[bwtrailerhitches.com](http://bwtrailerhitches.com)

# MODEL 1325

2019-2026 Ram 1500 Trucks  
Excludes RAM 1500 Classic Trucks  
Excludes RAM TRX Trucks

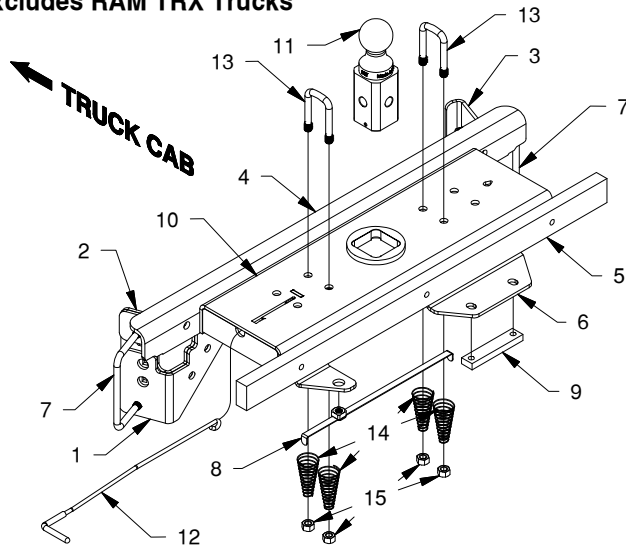

Mounting Kit Box (GNRM1325)		
ITEM	DESCRIPTION	QTY
1	Outside Driver Side Plate	1
2	Inside Driver Side Plate	1
3	Passenger Side Plate	1
4	Front Cross Member	1
5	Rear Cross Member	1
6	Rear Brace	1
7	1/2" X 5-1/2" X 4-1/4" U-Bolt	2

Center Box (GNRC825)		
ITEM	DESCRIPTION	QTY
10	Center Section	1
11	2-5/16" Ball	1
12	Latch Pin Handle	1

Safety Chain Kit Bolt Bag		
ITEM	DESCRIPTION	QTY
13	1/2" U-Bolt	2
14	Conical Springs	4
15	1/2" Lock Nut	4
	5/16" X 3/4" Carriage Bolt	1
	5/16" X 3/4" Cap Screw	1
	5/16" Lock Nut	1

Mounting Kit Bolt Bag		
ITEM	DESCRIPTION	QTY
8	Welded Nut Guide	1
9	Threaded Block	1
	1/2" X 2-1/4" Cap Screw	2
	1/2" X 1-1/2" Cap Screw	11
	1/2" Flat Washer	10
	1/2" Lock Washer	17
	1/2" Finish Nut	11
	5/16" X 3/4" Carriage Bolt	2
	5/16" Serrated Flange Nut	2

**NOTICE:** The 2-5/16" ball installs over the axle. Take this into consideration when choosing and installing accessories for this hitch.

### ⚠ WARNING

**Failure to comply with the safety information in these instructions could result in serious injury or death.**

- ⚠ Read all installation and operating instructions along with all labels before installing or using this product.
- ⚠ Adding components such as a Turnoverball hitch to the chassis of any vehicle can be hazardous. There is potential for unexpected combustion of fuel, electric shock, burns, shifting or falling of unstable vehicle, damage to vehicle, injury from tool usage and many other hazards. This installation must be completed by someone who is aware of the hazards involved. This person must be knowledgeable of proper safety procedures for a vehicle modification of this nature, and for usage of the equipment required to perform the installation.
- ⚠ Without proper knowledge, towing can be a dangerous activity. Understand all the risks involved with towing before proceeding. For information on towing safety, see "**The Trailer Handbook: A Guide to Understanding Trailer and Towing Safety**" from the National Association of Trailer Manufacturers, [www.NATM.com](http://www.NATM.com) and your trailer manufacturer's owner's manual.
- ⚠ Do not exceed tow or tongue rating of coupler, tow or tongue rating of hitch, or tow or weight ratings of truck or trailer. See vehicle and trailer manufacturer information for ratings. Exceeding these ratings may cause damage to towing components or loss of attachment between the trailer and truck.
- ⚠ Do not modify this product in any manner. Doing so could alter its integrity and lead to a loss of attachment between the trailer and the tow vehicle.
- ⚠ Additional caution must be used when towing a wedge car trailer. Towing stability greatly depends on keeping the center of gravity as low as possible. Load heavy cars over the axles. Never tow with a single car on the front of the trailer. When towing a wedge car trailer, never exceed speeds that are reasonable for the roadway conditions (e.g. turns, going around a curve, etc.). Failure to account for proper trailer center of gravity and speeds that are reasonable for the roadway conditions may cause damage to the truck, trailer, towing components, and loss of attachment between the truck and trailer.
- ⚠ This product was designed to fit vehicles in their original, "as manufactured" condition. Compatibility with vehicles having replacement parts, or other modifications is not guaranteed. Inspect vehicle for modifications before installation of this product.
- ⚠ The Turnoverball hitch comes equipped with a 2-5/16" ball. Trailers towed with the ball provided must have a 2-5/16" coupler. Towing with a larger coupler could cause loss of attachment between the trailer and the tow vehicle.
- ⚠ A visual inspection of the hitch should be performed before each time you tow. Regularly check that all pinned connections are secure, and that all bolted connections are at the correct torque specification. Check for cracks or damage to the hitch. Do not tow with the hitch if cracks or damage outside of normal wear is found. Towing with a hitch that has cracks or damage could result in damage to the tow vehicle, trailer, towing components or loss of attachment between the tow vehicle and trailer.

# PREPARE TO INSTALL

**NOTE:** Remove all parts from the packaging and familiarize yourself with all the parts and tools required. Use the parts list on the front page to verify that all parts and hardware are present.

Installation of the Turnoverball hitch requires several common tools and a few specialized tools. Below is a listing of equipment used during a typical installation.

## TOOLS REQUIRED

- Impact wrench or ratchet with 3/4" & 6mm socket.
- 2025 and newer trucks, 13mm socket.
- 1/2", & 3/4" Box end wrench
- Marking tool (pencil or permanent marker)
- 4" hole saw
- Drill with 1/2" bit
- Ear protection
- Pry bar
- Lifting device
- 10mm socket or wrench
- Flashlight
- Eye protection
- Torque wrench
- Tape measure
- Pilot hole bit
- Wire ties

1. **Determine cab clearance.** The Turnoverball hitch is designed so that the ball can be inverted and stored below the surface of the truck bed while not in use. The ball location is determined by this design feature and the truck geometry. Measure the trailers to be towed with this hitch to be sure that the location of the 2-5/16" ball listed in Step 8 will provide ample turning clearance between the nose of the trailers and the cab of the truck.

**WARNING:** Cab clearance on short bed trucks is very limited when towing certain trailers. Failure to ensure that there will be adequate clearance, may result in significant property damage, or serious injury.

2. **Position the vehicle.** Installation of the hitch requires the installer to be under the truck bed in the area of the rear axle. Lifting the vehicle makes this area more accessible to the installer, and improves the installation process.

**WARNING:** Lift vehicle using only equipment designed for lifting and positioning vehicles for service. Failure to do so may result in property damage, serious injury, or death.

3. **Remove the spare tire.** Following the vehicle manufacturer's instructions, remove the spare tire. This will provide easier access to the area where the hitch will be installed. Remember to replace tire when installation is completed.

4. **Remove inner fender guards.** Some trucks are equipped with plastic fender guards in the wheel wells. Smaller guards at the front and rear of the wheel well may not interfere with installation. If large middle guards are present they will need to be removed at this time.

5. **Remove spare tire heat shields.** Remove the two spare tire heat shields by unbolting the six 6mm or 13mm bolts. Retain the bolts for later re-installation.
6. **Disconnect exhaust.** The exhaust must be lowered to install the hitch components. Disconnect the exhaust from the frame at the rear most exhaust hangers so that it hangs free.
7. **Prepare a lifting device (optional).** The purpose of the device is to safely hold the hitch in position during part of the installation. See Figure A1 for an example. A simple mechanical lifting device is available for purchase from B&W.

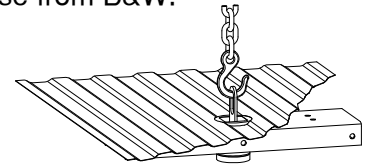

Figure A1.

8. **Mark the 4" hole location.** Using a tape measure hooked over the rear edge of the bed (at tailgate end), measure the location for the hole, as shown in Figure A2. Next, locate the center of the bed by measuring the distance between the wheel wells and dividing by two. The center of the hole will be at the intersection of the center of the bed and the first distance measured.

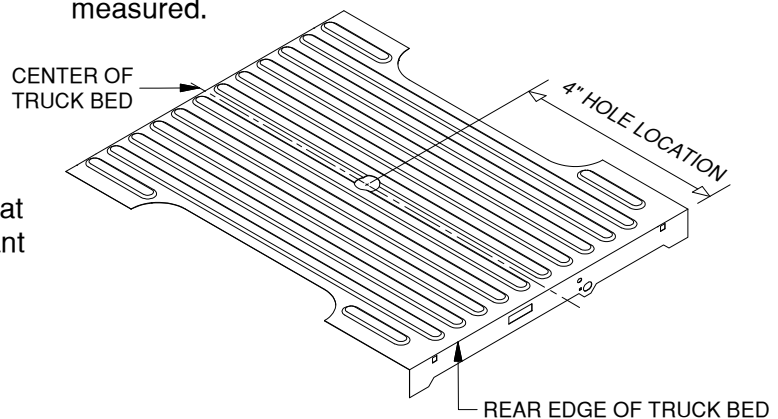

Figure A2.

## 4" HOLE LOCATION SHORT BED (BEDS LESS THAN 8' LONG) - 39-3/8"

**IMPORTANT:** The hitch is designed to install only at the described location. Failure to place the 4" hole precisely may result in added difficulty during installation or property damage.

**IMPORTANT:** If the bed is equipped with a plastic bed liner, the hole may be cut through both the liner and the bed. However, the center of truck bed may be more difficult to locate, and the mark may be harder to hit if the liner slides or moves. Failure to cut the hole in the correct location may adversely affect the install and may result in property damage.

**IMPORTANT:** If your truck has a spray-in bed liner you will need to take this into account when you are measuring, and add the thickness of the applied liner that has been sprayed over the end of the bed.

Continued on next page...

- Cut the 4" diameter hole.** Cut the hole in the marked location using a 4" hole saw or by marking out the 4" hole and using a saber saw equipped with a metal cutting blade. Remove any burrs created while cutting hole.

**WARNING:** Turnoverball hitch components are heavy and may be cumbersome to handle. Failure to use proper lifting techniques and caution when handling these items could result in serious injury.

**WARNING:** Most trucks have fuel lines, brake lines, electrical wires or other vehicle systems located along the frame rails or in the general area where B&W Turnoverball hitches install. Carefully examine the locations of these systems before installation. Make certain that these are not damaged during positioning hitch components, drilling holes, or tightening fasteners. Damage to these systems may result in property damage, serious injury, or death.

*DIAGRAM NOTE: Instruction steps show installation in a dual exhaust truck. Installation may vary slightly for trucks without a factory dual exhaust.*

## NOTICE: ADDITIONAL INSTRUCTIONS FOR 2025 AND NEWER TRUCK MODELS.

- Loosen muffler exhaust hanger.** For 2025 and newer vehicles, the muffler exhaust hanger must be loosened to provide adequate clearance for installation. Use a 13mm socket to loosen the two M8 nuts securing the hanger until it hangs down as far as possible, see Figure A3. The nuts do not need to be removed from the threaded studs.

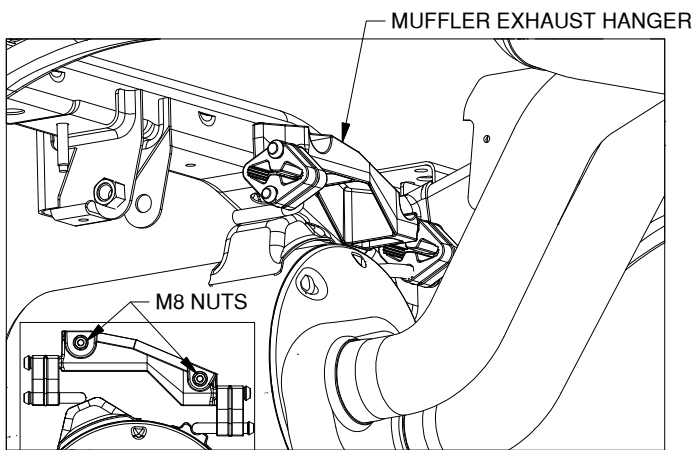

Figure A3: View under truck looking up at muffler hanger.

## INSTALL REAR CROSS MEMBER

- Detach wiring harness bracket.** Locate the metal wiring harness bracket on the rear frame cross member, as shown in Figure B1. Remove the 6mm bolt holding the bracket to the frame. Carefully cut the two plastic ratchet plug fasteners to remove the bracket from the wiring and discard the bracket.

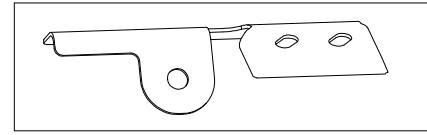

Figure B1: Truck frame cross member wiring bracket.

- Detach driver side wiring and vent tube.** A wiring harness and a vent tube run along the top of the driver side frame and the frame cross member that is just behind the axle. These sections of the wiring harness and vent tube must be detached from the frame before installation. The harness is secured to the top of the cross member and frame by ratchet plug fasteners. During the hitch installation, the wiring harness will need to be moved and adjusted to keep the wiring from getting pinched or damaged. It may also be necessary to un-plug the wiring harness in some areas.
- Detach passenger side wiring.** A wire leading to the outside of the passenger side wheel well runs along the rear frame cross member. It must be unplugged and disconnected from the top of the frame cross member and left to hang behind the rear frame cross member until the installation is complete.
- Place the rear cross member.** The rear cross member is the 2" x 1" bar with three threaded holes. Pass the cross member over the axle on the driver side of the differential from the rear. Angle the leading end of the bar toward the passenger side of the frame while going in front of the exhaust. Place the trailing end of the bar over the driver side frame rail, as shown in Figure B2. Swing the leading end of the cross member over the passenger side of the frame so that it is parallel with the axle. Rotate the bar so that the threaded holes are horizontal, and the bar is sitting on top of the frame cross member. Slide the bar rearward until it is touching the bed cross member. Make sure that the wiring harness does not get pinched or smashed while moving the cross member rearward.

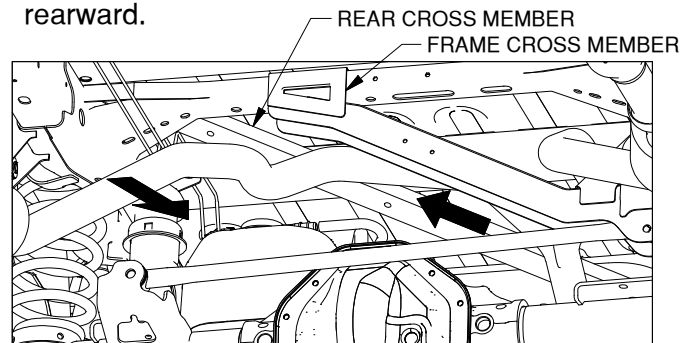

Figure B2: View looking under truck bed toward the cab.

# INSTALL CENTER SECTION AND FRONT CROSSMEMBER

**NOTICE.** If your truck has a four-corner air suspension, extra steps are required before installing the front cross member. An air line and a wiring harness running along the inside of the passenger side frame will need to be disconnected, pulled away from the frame and rerouted along the top of the frame. Push the air lines and wires to the outside of the frame so they lay along the vertical flange of the truck bed. There are also air lines on the driver side of the frame that will need to be loosened and pushed up over the frame so that there is space to place the end of the front cross member over the frame. Do not damage the rigid air components protruding from the top of the air bags when moving the front cross member into place.

1. **Exhaust configuration.** If your truck has a single exhaust skip to Step 3. For dual exhaust continue to Step 2.
2. **Position the center section (dual exhaust).** When maneuvering the center into position, the exhaust will need to have downward force applied to it to open up the space below the bed where the center will install. From behind the axle, move the center section over the driver side of the axle toward the passenger side with the latch pin on the driver side. Lift the center up over the exhaust where it splits, as shown in Figure C1. Lower the driver side exhaust and "roll" the center section over the exhaust, as shown in Figure C2. Do not put the 4" diameter raised area of the center into the 4" hole in the bed at this time. Move the center as far toward the rear of the truck and to the passenger side as possible to make room for the front cross member. Position the center in a secure manner so that it will not fall while completing the installation.

3. **Position the front cross member (dual and single exhaust).** The front cross member is the 2" x 2-1/2" angle with five holes in one flange. While holding the front cross member in an inverted "V" with the flange with holes in it toward the passenger side of the truck, move the cross member over the driver side of the rear axle, as shown in Figure C3. Lift the trailing end toward the rear of the truck over the driver side frame rail, see Figure C4. Slide the cross member toward the driver side until the leading end of the cross member can be placed on top of the passenger side frame rail. It may be necessary to adjust the wiring in the driver side wheel well to give the cross member clearance on the frame. When the cross member is spanning both frame rails, push the front cross member forward to make room to install the center.

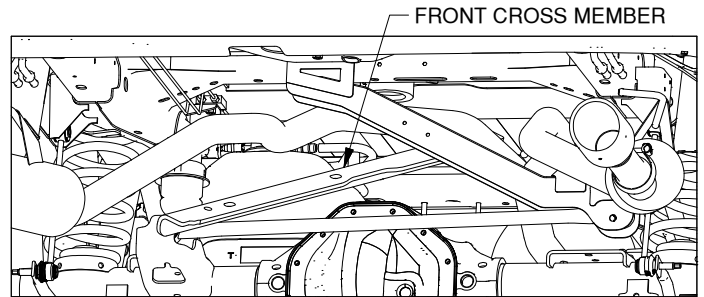

Figure C3: View looking under truck bed toward the cab.

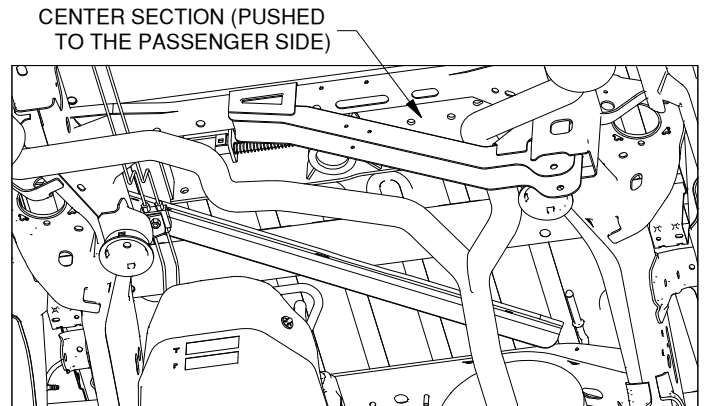

Figure C4: View looking up under truck bed. (Axle not shown)

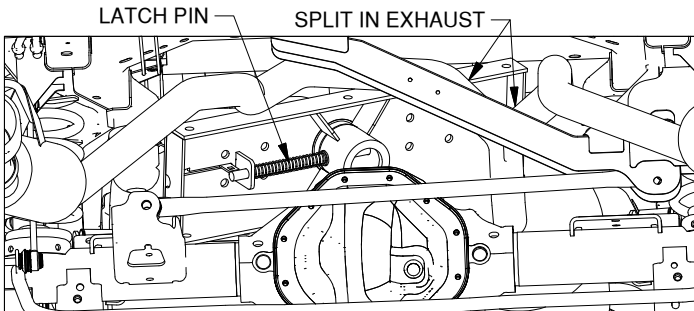

Figure C1: View looking under truck bed toward the cab.

4. **Install center section.** From under the bed, move the center section so that the 4" diameter raised area of the center fits into the 4" diameter hole in the truck bed. If available, an overhead lifting device can be attached to the latch pin of the center section at this time to apply upward pressure on the center, holding it in place. The latch pin and spring should be on the driver side of the center section.

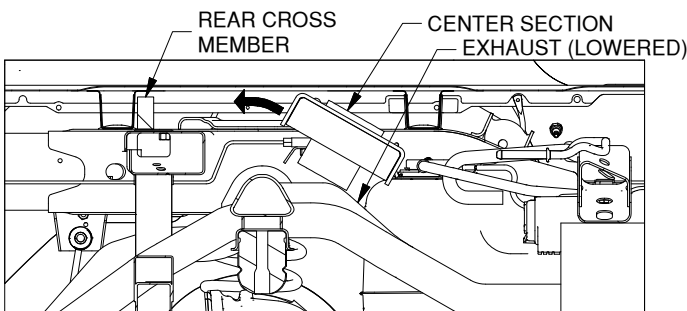

Figure C2: Cut-away view looking toward the inside of the driver side frame.

Continued on next page...

5. **Attach the rear cross member.** Slide the rear cross member forward until it contacts the center section. Line the holes in the rear cross member up with the slots in the center. A pry bar or screwdriver may be used to help position the cross member. Thread a 1/2" x 1-1/2" long bolt into the center rear hole in the center section into the center threaded hole in the rear cross member, adding a lock washer to the connection, as shown in Figure C5. Hand tighten hardware at this time.

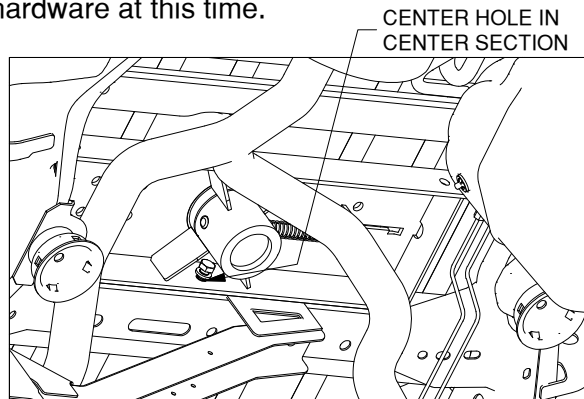

Figure C5: View looking up under truck bed from in front of the axle toward the rear of the truck. (Axle not shown)

6. **Attach the front cross member.** Push the front cross member back against the center section. Center the cross member in the truck so that the slots in the front cross member will line up with the holes in the center. Using an adjustable wrench on the longer flange of the part rotate the front cross member so that the flange with the holes is vertical, see Figure C6. The vertical cross member flange has a profile cut into it that will allow it to be rotated while it is centered in the truck and located over the coil spring mounts on top of the frame. Make sure no part of the wiring harness gets pinched between the frame and the hitch parts. Attach the center and the cross member with a single 1/2" x 1-1/2" long bolt in the center hole only, as shown in Figure C7. The bolt head must be toward the rear of the truck. Add a flat washer, lock washer, and finish nut to the bolt and hand tighten. Do not fully tighten at this point.

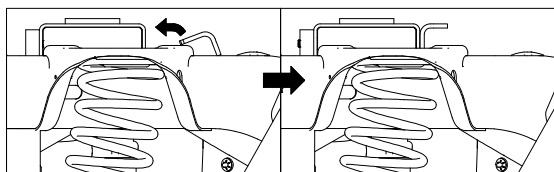

Figure C6: Cut-Away view of passenger side of frame (Bed not shown)

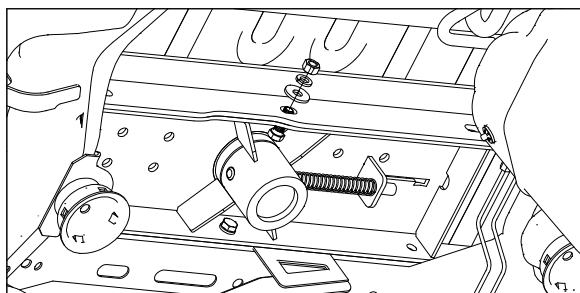

Figure C7: View looking up under truck bed from in front of the axle toward the rear of the truck. (Axle and exhaust not shown)

## INSTALL SIDE PLATES

1. **Place the U-bolts.** Place one U-bolt in front of each coil spring around the pickup frame as shown in Figure D1. To ease installation of the side plates, start with the U-bolts pulled back from the frame so that the ends of U-bolts are flush with the wall of the tubular frame, see Figure D2.

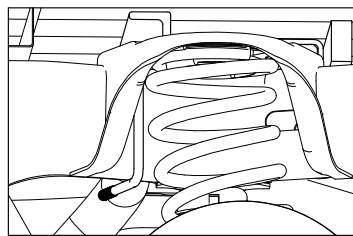

Figure D1: View of driver side suspension spring (Tire not shown)

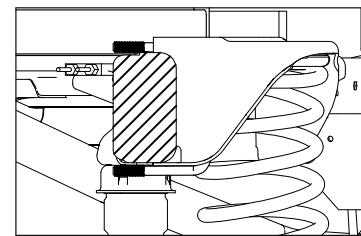

Figure D2: Cutaway view of suspension spring area looking toward the rear of the truck

2. **Install passenger side plate.** Locate the passenger side plate. Position the side plate so that the two round holes match up to the U-bolt on the passenger side and push the U-bolt into the holes, see Figure D3. Secure the side plate and U-bolt with lock washers and nuts. Attach this side plate to the front cross member, and center using a 2-1/4" long bolt through the center, cross member and side plate along with a lock washer, flat washer, and a finish nut. Finish attaching the side plate by placing 1/2" x 1-1/2" long bolt through the cross member and the side plate adding a flat washer, lock washer, and finish nut. Hand tighten these connections.

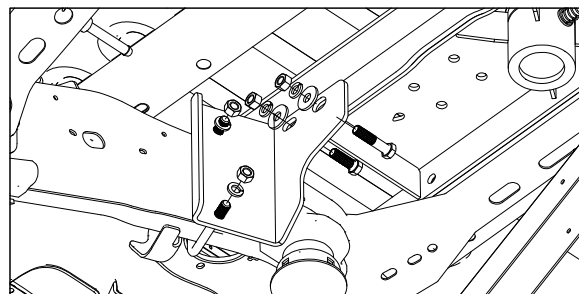

Figure D3: View of passenger side plate looking up at the frame.

**NOTICE:** If your truck has four-corner air suspension, when the passenger side plate is installed, the air line and wiring harness should transition from the inside of the frame to the top in front of the side plate. These lines should continue around the hitch components on top of the frame toward the outside of the frame.

**NOTICE:** For trucks equipped with a fuel tank skid plate. The support attached to the frame behind the tank must be relocated. Detach the support from the frame and loosen its connection with the skid plate. Before placing the inside driver side plate, install two 5/16" carriage bolts into its square holes so the bolt heads will be toward the frame. Hold the bolts in place with the two flange nuts. Install side plate and secure it as described in Step 3. Remove the 5/16" flange nuts and mount the skid plate support to the side plate using the carriage bolts and secure with the flange nuts. Tighten the lower skid plate connection.

3. **Install the driver side plates.** The two side plates that are left will be combined to secure the hitch to the frame on the driver side. Using the slot provided, maneuver the outside side plate around the brake lines and line the holes up with the U-bolt, see Figure D4. The wiring harness may lay in this slot to prevent it from being pinched by the U-bolt, side plate, or cross member. Insert the U-bolt into the holes on the side plate just enough to hold the side plate in place. Position the inside side plate over the first, as shown in Figure D5. Insert the U-bolt into the holes of the inside side plate. Secure the side plates and U-bolt with lock washers and nuts, as shown in Figure D6. Fasten the two side plates together using 1/2" x 1-1/2" long bolts, lock washers and finish nuts. Attach these side plates to the front cross member and center using a 2-1/4" long bolt through the center, cross member and side plate along with a lock washer, flat washer, and a finish nut. Finish attaching the side plates by placing a 1/2" x 1-1/2" long bolt through the cross member and the side plates adding a flat washer, lock washer, and finish nut, see Figure D7. Hand tighten these connections.

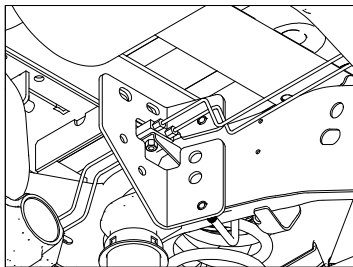

Figure D4

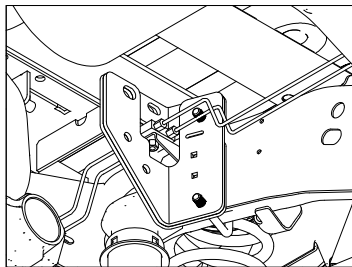

Figure D5

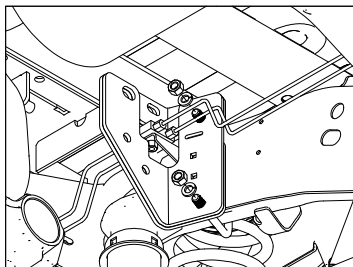

Figure D6

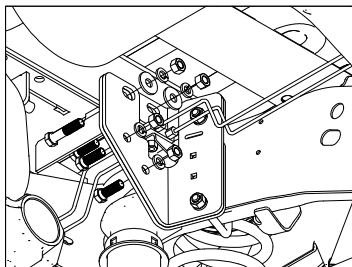

Figure D7

Figures D4 - D7: View of driver side plates looking up at the driver side frame. (Fuel tank and exhaust not shown.)

## INSTALL REAR BRACE

1. **Locate the threaded fastener guides.** The mounting kit contains a threaded block and a welded nut guide. Both are needed to install the rear brace, see Figure E1. **Note:** Inspect the welded nut guide to be sure that it is straight between the two bends and modify as needed, see below.

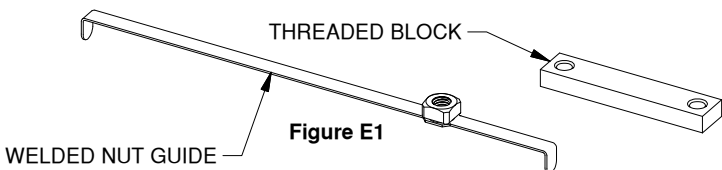

Figure E1

2. **Install the bolt guides.** Locate the rear frame cross member. First, install the threaded block by passing it through the slot in the frame cross member, as shown in Figure E2. The side of the threaded block which has the chamfered holes needs be down. Move the threaded block to the location shown in Figure E5. Second, with the welded nut guide on edge and the flanges facing the cab, install the guide by passing it through the slot, as shown in Figure E3. After the nut is in the tube turn the flanges so they are facing down. Pass the nut guide into the slot until the end of the guide is visible in the hole in the cross member on the driver side of the frame. Pass the end of the guide through the hole, as shown in Figure E4.

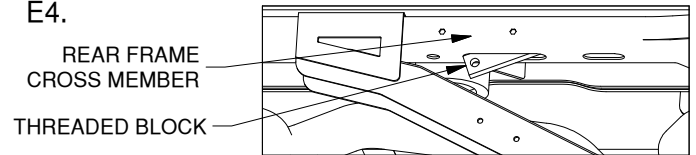

Figure E2

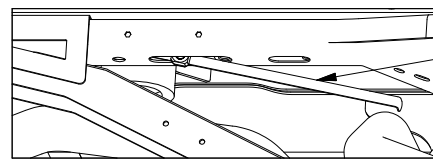

Figure E3

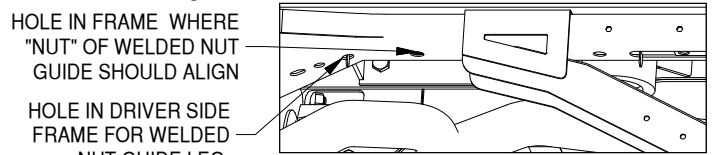
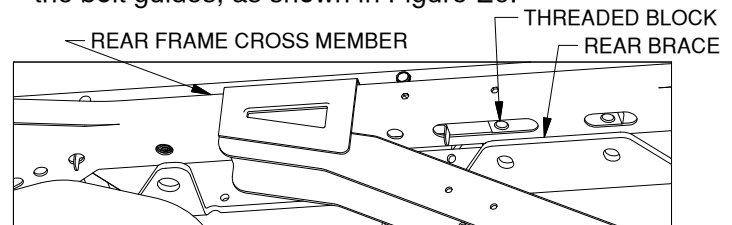

Figure E4

Figures E2 - E4: View under bed looking toward the cab.

3. **Install the rear brace.** The rear brace connects to both the center section and the rear frame cross member. Orient the rear brace as shown in Figure E5. Attach the brace to the center section by threading two 1/2" X 1-1/2" cap screws, flat washers, and lock washers, through the brace and into the rear cross member. Align the threaded block in the frame cross member with the holes in the rear brace. Attach the bottom of the brace to the frame cross member by attaching three 1/2" X 1-1/2" cap screws, flat washers, and lock washers into the bolt guides, as shown in Figure E6.



Figures E5: View under bed looking toward the cab.

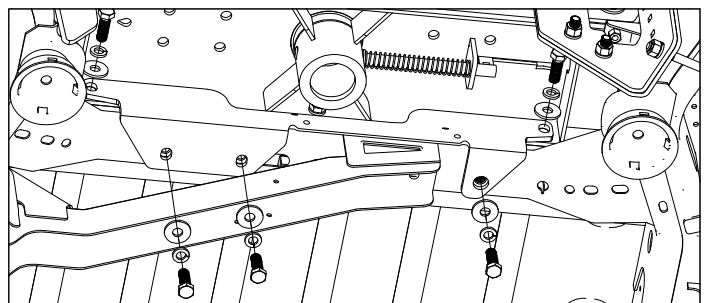

Figures E6: View under bed looking back toward the rear of the truck. (Exhaust not shown)

# TIGHTEN HARDWARE

1. **Before tightening.** With a tape measure, check that the hitch is centered and square in relation to the truck frame or bed. Next, check that the center section is tight against the bottom of the truck bed. Double check that no wiring is pinched and that all hitch components remain centered and square as hardware is tightened.

2. **Tighten the hitch hardware in the following sequence:**

**1st.** While holding the two driver side plates so that their edges are matched up as closely as possible, tighten the two bolts that hold the two side plates together to 80 ft. lbs.

**2nd.** Tighten the single 1/2" cap screw attaching the center to the front cross member to 110 ft. lbs.

**3rd.** Tighten the single 1/2" cap screw attaching the center to the rear cross member to 110 ft. lbs.

**4th.** While holding the rear brace snugly against the inside of the center section, tighten the three 1/2" cap screws holding the bottom flange of the rear brace to the bottom of the frame cross member to 110 ft. lbs.

**5th.** Tighten the two 1/2" bolts attaching the rear brace to the center section to 110 ft. lbs.

**6th.** Tighten the four 1/2" bolts attaching the side plates to the front cross member to 110 ft. lbs.

**7th.** Tighten both side plate U-bolts to 40 ft. lbs. Alternate tightening between the top and bottom nuts so the U-bolts will be secured evenly.

**! WARNING:** Failure to follow the bolt tightening sequence as listed may result in the hitch components being misaligned which could affect the performance of the hitch, or result in property damage, or serious injury.

3. **Disengage lifting device.** If a lifting device was used to hold the center section in place during the installation, remove it at this time.

# INSTALL LATCH PIN RELEASE HANDLE

**IMPORTANT:** The latch pin will not function properly if handle is not installed correctly.

1. **Modify the driver side fender liner if needed.** If the driver side fender liner was removed earlier it will need to be modified by cutting an access hole for the latch pin handle. Cut a 3" x 2" rectangle which has its top edge aligned with the two mounting holes and is roughly 6" forward of the rear mounting hole, see Figure F1. Loosely install the fender liner back into the wheel well.

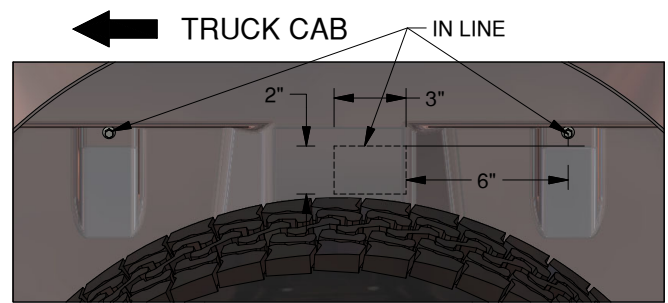

Figure F1.

2. **Secure the handle.** From the driver side wheel well, install the latch pin release handle by inserting it between the bed and the frame. Pass the eye of the handle through the slot in the end of the center section. Align the handle eyelet with the square hole in the latch pin so the handle is in line with the latch pin. (On the cab side of the tab). Secure the handle to the pin with the 5/16" X 3/4" carriage bolt and 5/16" locking flange nut, as shown in Figure F2. Note: The included 5/16" cap screw can replace the carriage bolt if wrench access on the "cab side" of the handle is limited. Tighten the nut until it is secure. Do not over-tighten and deform the handle eyelet.

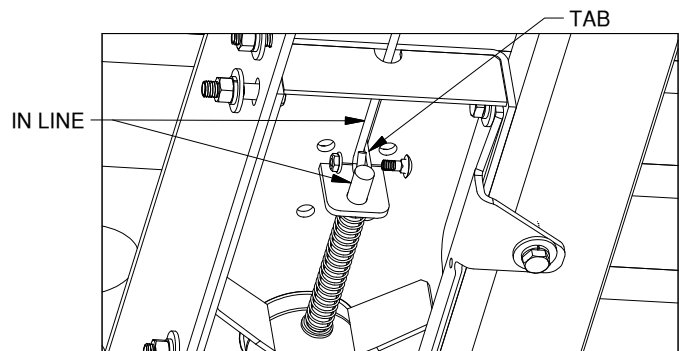

Figure F2: View under driver side of center under the latch pin. (Frame and some hitch components not shown.)

3. **Check handle operation.** If the driver side fender liner was removed earlier, retract the latch pin by pulling the handle all the way out until it stops and then rotate it clockwise. Make sure that the liner does not interfere with handle operation. If the handle needs additional clearance, modify the liner then reinstall and secure tightly. Re-install the passenger side fender liner.

# INSTALL SAFETY CHAIN U-BOLTS

This Turnoverball hitch is equipped with holes in the center section for mounting safety chain U-bolts. The hitch is designed so that the U-bolts will be in or near a low rib of the truck bed. The center section of the hitch may have more than one set of holes. One set of holes should match up with a low area in the truck bed. Carefully examine the safety chain holes in the center section to determine which holes are under a low area, see Figure G1.

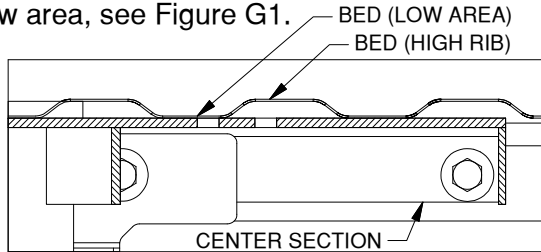

Figure G1: Cutaway view of bed and center section.

1. **Drill the holes.** From under the bed use a drill and a 1/2" drill bit to drill through the bed using the four holes that match up with a low area in the truck as a guide. Remove any burrs created during the drilling process.
2. **Install the U-bolts.** From the top side of the truck bed, drop a u-bolt in each set of holes.
3. **Add springs.** Place a conical spring over each leg of the U-bolts and secure with a 1/2" lock nut, see Figure G2. Tighten the lock nut until the nut is flush with the end of the U-bolt.

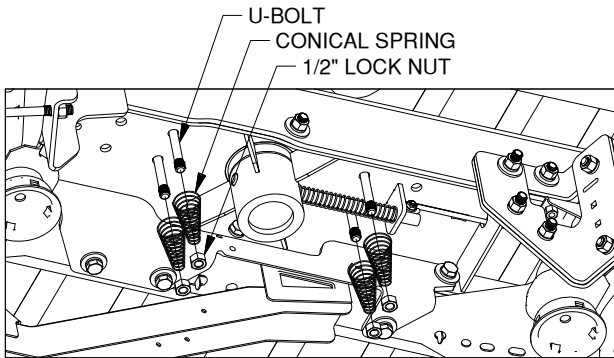

Figure G2: View under the bed looking back at the rear of the truck. (Exhaust not shown)

## PREPARE FOR TOWING

1. **Secure the wiring harnesses.** As space allows, re-secure the wiring harnesses which were detached from the driver side, passenger side, and the rear frame cross member. It may be necessary to use wire ties where hitch components are now blocking the original wiring harness routing. Also, re-plug in any parts of the harness that are un-plugged. All parts of the wiring harness should be secured well away from the exhaust. Re-secure the small wire plugged in on the passenger side wheel well behind the coil spring. The wire should pass between the rear hitch cross member and the bed cross member.

2. **Secure vent tube.** There is a vent tube that runs along parts of the wiring harness. Position it on top of the driver side frame. Secure it to the wiring harness if needed to keep it in place.
3. **Replace the spare tire heat shields and spare tire.** Replace the two heat shields removed at the beginning of installation. Then, using the manufacturer's instructions, replace the spare tire.
4. **Re-attach the exhaust.** Re-attach each of the exhaust hangers to the frame. On most trucks there should be clearance between the hitch hardware and the exhaust. If additional clearance is needed, the exhaust may need to be lowered or modified.

**WARNING:** Wiring harness must be secured away from the exhaust in a way that it will not move and contact the exhaust. Failure to permanently secure the wiring harness could lead to property damage.

5. **Check latch pin operation.** Retract the latch pin by pulling the handle all the way out until it stops and then rotate it clockwise. Place the 2-5/16" ball in the hitch receiver. Engage the latch pin by rotating the handle counterclockwise.

**WARNING:** The handle is close to the bed flange. This is a potential pinch point. The handle needs to pass under the bed flange freely so that it does not get stuck before the pin is fully engaged.

**WARNING:** When installed properly the latch pin will pass through the 2-5/16" ball and fully engage through both walls of the hitch receiver. Failure of the pin to engage the ball and hitch properly could result in a loss of attachment between the trailer and the tow vehicle.

6. **Lubricate 2-5/16" ball.** Apply a light coating of grease to the corners on the square shank of the 2-5/16" ball.

**WARNING:** Inverting the ball while hauling heavy loads may cause the ball to strike the truck's differential, drive line, or other components. Inspect the relationship between the ball and truck components to ensure the proper clearance. Failure to remove the ball when hauling heavy loads may result in property damage, injury or death. A cover to prevent debris from entering the socket while operating without the ball in place is available from B&W.

7. **Re-read front page.** Re-read all warnings on front page of these instructions. If you are not the end user, make sure that users of this product receive a copy of these instructions.