

<THESE INSTRUCTIONS MUST BE GIVEN TO THE END USER>



B&W Trailer Hitches
1216 Hawaii Rd / PO Box 186
Humboldt, KS 66748
P:800.248.6564
F:620.869.9031

See Limited Lifetime Warranty at bwtrailerhitches.com/warranty

**Call or Email us for
Installation Support**
hitches@turnoverball.com
bwtrailerhitches.com

Receiver Hitch Installation Instructions

MODEL RH610117,
RH610117BW

2017 - 2024 Honda CR-V

MAXIMUM TOW RATING (GTW): 4500LBS
MAXIMUM TONGUE WEIGHT (VTW): 675 LBS

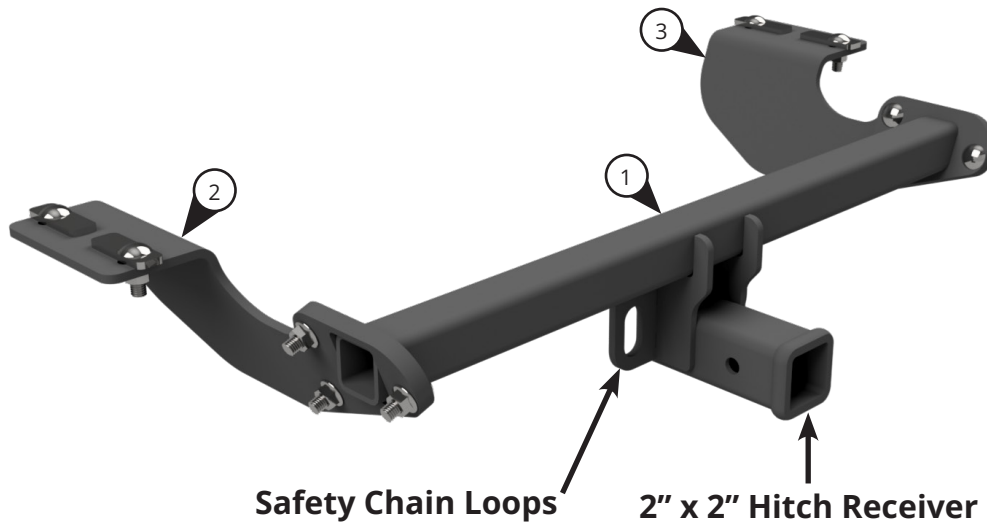

BOX: RH610117		
#	DESCRIPTION	QTY
1	Hitch Frame	1
2	Driver Side Plate	1
3	Passenger Side Plate	1
	Fish Wire	4

BOLT BAG: 2110-610117-00	
DESCRIPTION	QTY
1/2" x 1-1/4" Carriage Bolt	10
1/2" Flange Nut	10
1/2" Flange Nut	4

IMPORTANT SAFETY NOTICE FOR HITCH INSTALLERS AND CUSTOMERS.

Read all installation and operating instructions along with all labels before installing or using this product.

⚠️ WARNING

Failure to comply with the safety information in these instructions could result in serious injury or death.

- ⚠️ Do not modify this product in any manner. Doing so could alter its integrity and lead to a loss of attachment between the trailer and the tow vehicle.
- ⚠️ Adding components to the chassis of any vehicle can be hazardous. There is potential for unexpected combustion of fuel, electric shock, burns, shifting or falling of unstable vehicle, damage to vehicle, injury from tool usage and many other hazards. This installation must be completed by someone who is aware of the hazards involved. This person must be knowledgeable of proper safety procedures for a vehicle modification of this nature, and for usage of the equipment required to perform the installation.
- ⚠️ Do not exceed tow or tongue rating of coupler, tow or tongue rating of hitch, or tow or weight ratings of tow vehicle or trailer. See vehicle and trailer manufacturer information for ratings. Exceeding these ratings may cause damage to towing components or loss of attachment between the trailer and vehicle.
- ⚠️ This product was designed to fit vehicles in their original, "as manufactured" condition. Compatibility with vehicles having replacement parts, or other modifications is not guaranteed. Inspect vehicle for modifications before installation of this product.
- ⚠️ A visual inspection of the towing components should be performed before each use. Regularly check that all connections are secure, including those that secure the hitch to the vehicle. Check for cracks or damage to the hitch, tow vehicle receiver, trailer coupler and frame. Do not use the hitch if cracks or damage outside of normal wear is found. Using a hitch that has unsecure connections and/or cracks or damage could result in damage to the tow vehicle, trailer, towing components and loss of attachment between the tow vehicle and trailer.
- ⚠️ Without proper knowledge, towing can be a dangerous activity. Understand all the risks involved with towing before proceeding. For information on towing safety, see **"The Trailer Handbook: A Guide to Understanding Trailer and Towing Safety"** from the National Association of Trailer Manufacturers, www.NATM.com and your trailer and tow vehicle manufacturer's owner's manual.
- ⚠️ Always use safety chains while towing. Crossing the safety chains under the tongue of trailer may prevent some damage to the trailer if detachment occurs.

NOTE: Use the parts list on the front page to verify that all parts and hardware are present.

TOOLS REQUIRED

- Torque wrench
- Impact wrench or ratchet
- Plastic pry tools
- 10mm & 3/4" sockets
- Safety glasses
- Ratchet strap
- Pry bar
- Flashlight
- Dremel tool
- File

PREPARE TO INSTALL



1. Under the rear of the vehicle, use a pry tool to remove seven plastic fasteners from the rock guard, see Figure A1. Use a 10mm socket to remove two nuts from the forward corners of the rock guard. Set the rock guard aside.

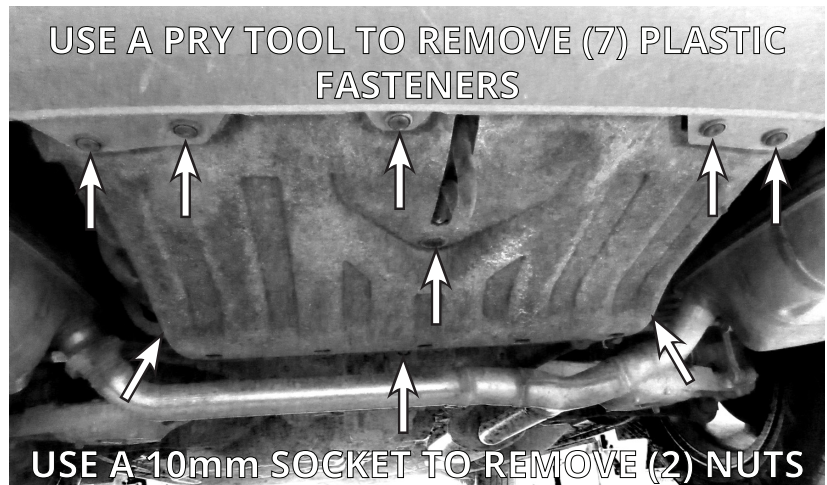

FIGURE A1: VIEW UNDER THE REAR OF THE VEHICLE



2. Attach a ratchet strap under the vehicle to support the exhaust. Above the exhaust are three rubber isolators, one in front of each muffler. Use a pry bar to disconnect the isolators from the exhaust, see Figure A2. Using the ratchet strap, lower the exhaust to gain access to the area above the exhaust.

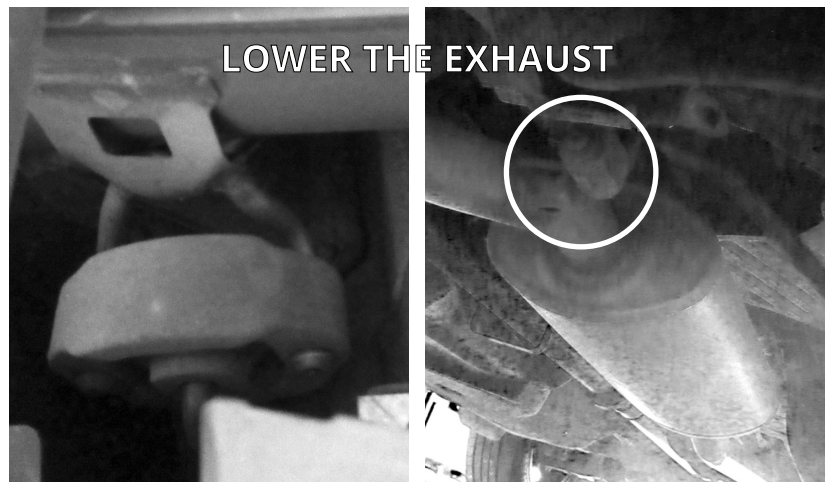

FIGURE A2: VIEWS UNDER THE VEHICLE

NOTE: Spray lubricant on the connection points to ease removal.

3. Under the rear of the vehicle, above the two rearward mufflers, identify the chassis channels where the holes for installing the side plates are located, see Figure A3.

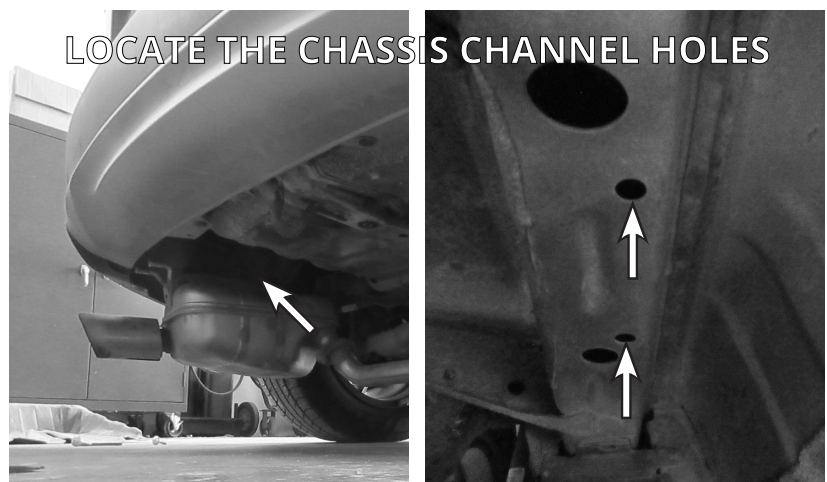

FIGURE A3: VIEWS UNDER THE VEHICLE

PREPARE TO INSTALL CONTINUED

4. Thread a carriage bolt and locking strap onto a fish wire. Pass the non-coiled end of the fish wire into the large hole at the end of the chassis channel through the channel and into the smaller forward hole, as shown in Figure A4. Insert the locking strap and carriage bolt into the channel through the large hole. Pull on the fish wire to bring the carriage bolt through the smaller hole.
5. Repeat the process described in Step 4 and place a carriage bolt into the smaller rearward hole as shown in Figure A4.

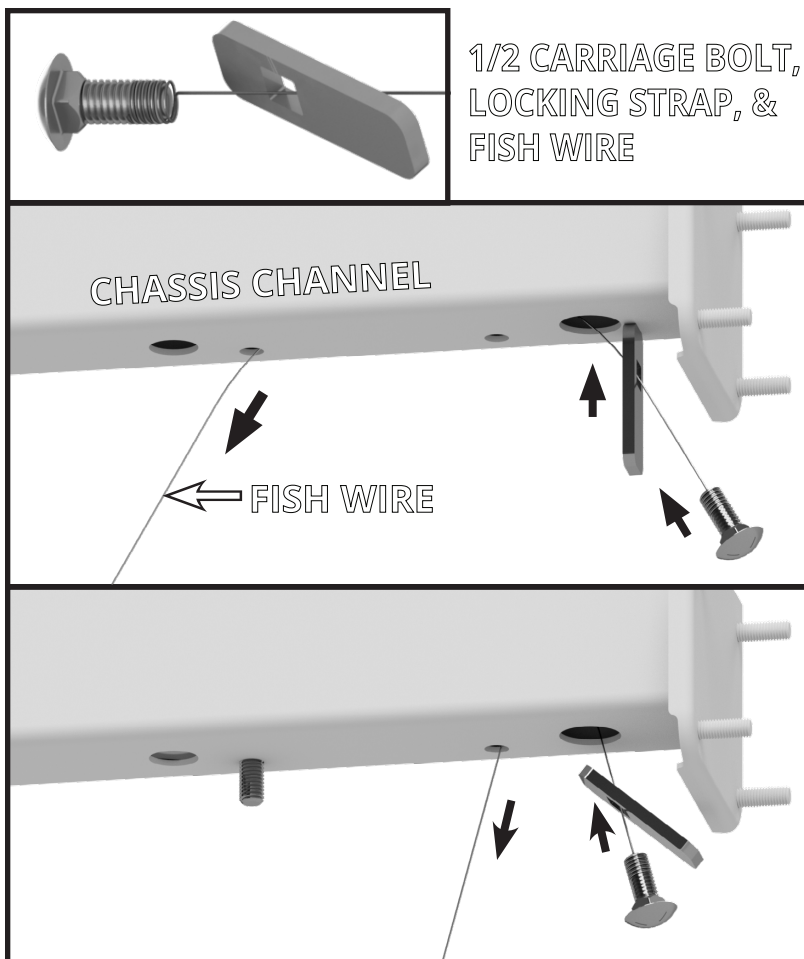

FIGURE A4: VIEW OF PASSENGER SIDE CHASSIS CHANNEL

4. The rear fascia (bumper) will need to be modified to allow the receiver to fit underneath the vehicle. With a Dremel tool, use the first image in Figure A5 to measure and cut the rectangle and tab. Next, cut the tab on the kick wand housing as shown in the second image. Smooth the cuts with a file.

NOTICE: Behind the fascia is a kick wand housing. Aside from the tab mentioned in the image, do not cut or modify the kick wand housing.

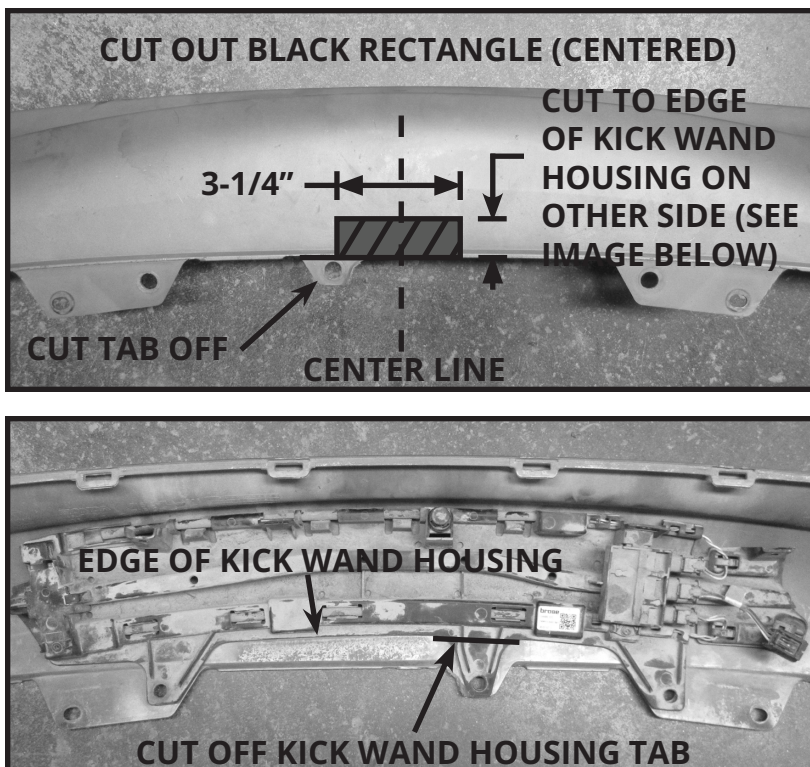

FIGURE A5: VIEW OF REAR FASCIA PARTS

INSTALL HITCH FRAME

- Attach each side plate to the vehicle using the two 1/2 x 1-1/4" carriage bolts that are positioned inside the chassis channels. Pass each side plate up over the bolts and secure them with two 1/2" flange nuts, as shown in Figure B1. Loosely attach bolts at this time.

NOTE: The side plates will be partially inside the fascia. Move any wiring that may be pinched between the side plates and the fascia out of the way.

LOOSELY ATTACH SIDE PLATES TO THE VEHICLE FRAME

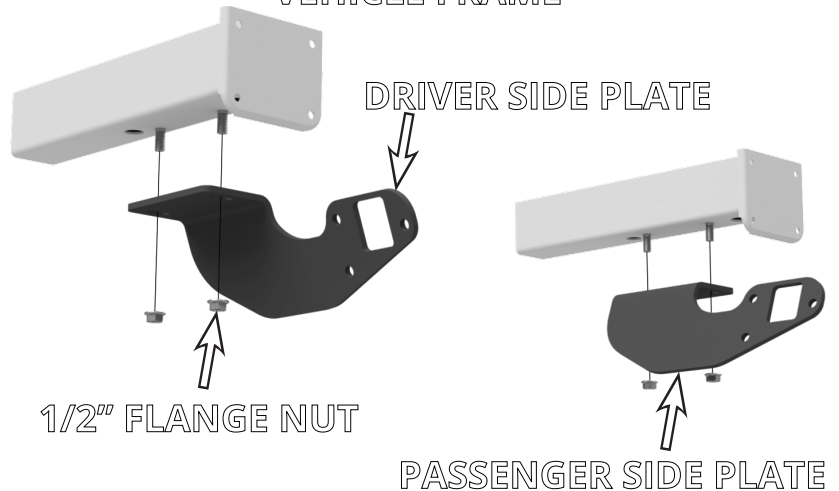

FIGURE B1: VIEW UNDER THE REAR OF THE VEHICLE



3/4"
SOCKET



TORQUE
WRENCH

- Raise the hitch frame up under the fascia and between the side plates, as shown in Figure B2. Use six 1/2" x 1-1/4" carriage bolts and six 1/2" flange nuts to secure the hitch frame to the side plates.
- Hand tighten all the hardware until the side plates are flush with the vehicle chassis and the hitch beam is centered in the vehicle.
- Tighten each bolted connection, then torque all ten flange nuts to 100 ft.-lbs.

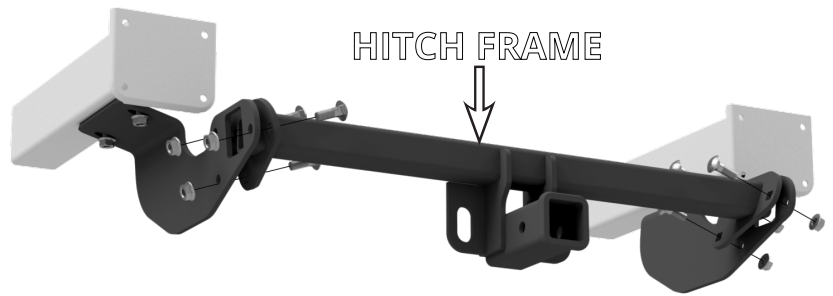

FIGURE B1: VIEW UNDER THE REAR OF THE VEHICLE

REINSTALL VEHICLE COMPONENTS

11. The rock guard will need to have piece cut out of it. With a Dremel tool, use the image in Figure C1 to measure and cut the rectangle. Smooth the cuts with a file.

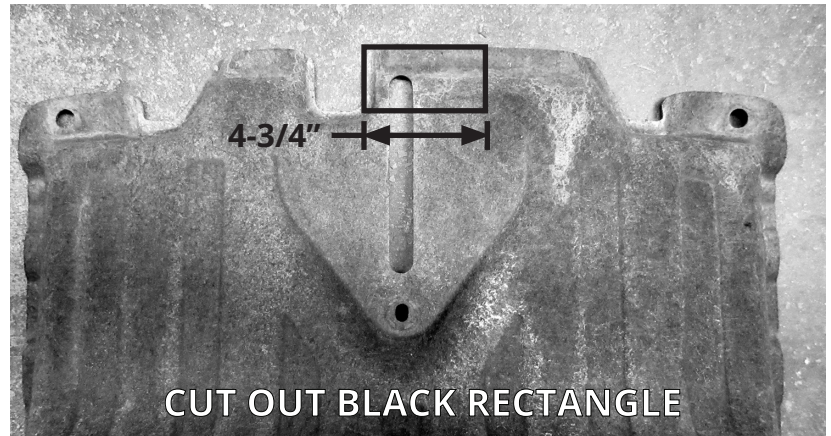

FIGURE C1: VIEW OF ROCK GUARD

12. Reattach the exhaust and rock guard. Refer to Steps 1-2. See Figure C2 for view of finished install from underneath the vehicle.



FIGURE C2: VIEW OF HITCH FRAME ASSEMBLY