

<THESE INSTRUCTIONS MUST BE GIVEN TO THE END USER>



B&W Trailer Hitches
1216 Hawaii Rd / PO Box 186
Humboldt, KS 66748
P:800.248.6564
F:620.869.9031

See Limited Lifetime Warranty at bwtrailerhitches.com/warranty

**Call or Email us for
Installation Support**
hitches@turnoverball.com
bwtrailerhitches.com

Receiver Hitch Installation Instructions

MODEL RH670220,
RH670220BW

2020-2024 Toyota Highlander

MAXIMUM TOW RATING (GTW): 5000 LBS
MAXIMUM TONGUE WEIGHT (VTW): 750 LBS

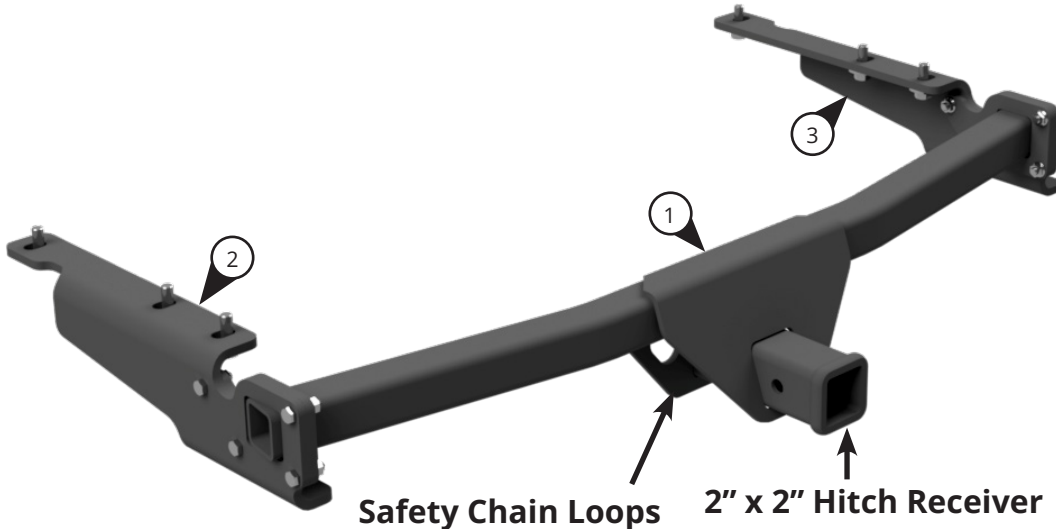

BOX: RH660118		
#	DESCRIPTION	QTY
1	Hitch Frame	1
2	Driver Side Plate	1
3	Passenger Side Plate	1

BOLT BAG: 2110-660118-00	
DESCRIPTION	QTY
M12 x 35mm Cap Screw	6
3/8" x 1-1/4" Cap Screw	8
3/8" Flange Nut	8
1/2" Conical Washer	6

IMPORTANT SAFETY NOTICE FOR HITCH INSTALLERS AND CUSTOMERS.

Read all installation and operating instructions along with all labels before installing or using this product.

⚠️ WARNING

Failure to comply with the safety information in these instructions could result in serious injury or death.

- ⚠️** Do not modify this product in any manner. Doing so could alter its integrity and lead to a loss of attachment between the trailer and the tow vehicle.
- ⚠️** Adding components to the chassis of any vehicle can be hazardous. There is potential for unexpected combustion of fuel, electric shock, burns, shifting or falling of unstable vehicle, damage to vehicle, injury from tool usage and many other hazards. This installation must be completed by someone who is aware of the hazards involved. This person must be knowledgeable of proper safety procedures for a vehicle modification of this nature, and for usage of the equipment required to perform the installation.
- ⚠️** Do not exceed tow or tongue rating of coupler, tow or tongue rating of hitch, or tow or weight ratings of tow vehicle or trailer. See vehicle and trailer manufacturer information for ratings. Exceeding these ratings may cause damage to towing components or loss of attachment between the trailer and vehicle.
- ⚠️** This product was designed to fit vehicles in their original, "as manufactured" condition. Compatibility with vehicles having replacement parts, or other modifications is not guaranteed. Inspect vehicle for modifications before installation of this product.
- ⚠️** A visual inspection of the towing components should be performed before each use. Regularly check that all connections are secure, including those that secure the hitch to the vehicle. Check for cracks or damage to the hitch, tow vehicle receiver, trailer coupler and frame. Do not use the hitch if cracks or damage outside of normal wear is found. Using a hitch that has unsecure connections and/or cracks or damage could result in damage to the tow vehicle, trailer, towing components and loss of attachment between the tow vehicle and trailer.
- ⚠️** Without proper knowledge, towing can be a dangerous activity. Understand all the risks involved with towing before proceeding. For information on towing safety, see **"The Trailer Handbook: A Guide to Understanding Trailer and Towing Safety"** from the National Association of Trailer Manufacturers, www.NATM.com and your trailer and tow vehicle manufacturer's owner's manual.
- ⚠️** Always use safety chains while towing. Crossing the safety chains under the tongue of trailer may prevent some damage to the trailer if detachment occurs.

NOTE: Use the parts list on the front page to verify that all parts and hardware are present.

TOOLS REQUIRED

- 9/16" Open end wrench
- Torque wrench
- Impact wrench or ratchet
- 3/4", 9/16", 19mm, 13mm & 10mm sockets
- Safety glasses
- Dremel tool & File
- 90 degree pick
- Flashlight

PREPARE TO INSTALL

1. During installation, the spare tire may be in the way and should either be removed or lowered approximately 2 feet, see Figure A1. Refer to the vehicle's user manual for specific instructions on tire removal.

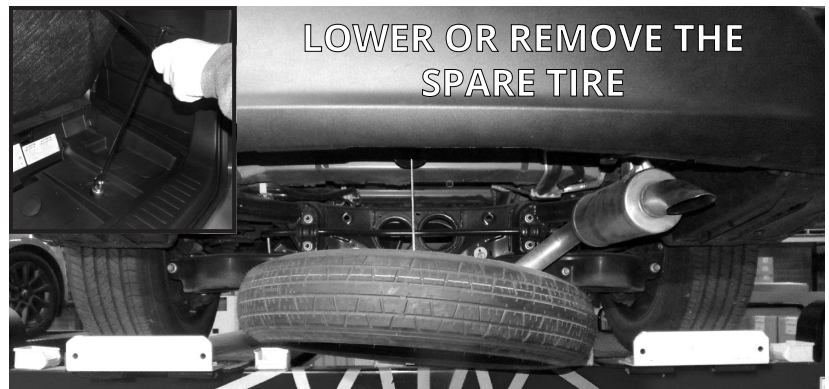
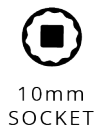

FIGURE A1: VIEW UNDER THE REAR OF THE VEHICLE



2. Under the rear corners of the vehicle, locate the two under body panels, shown in Figure A2. Using the tools listed below remove the panels.

A: Use a **10mm socket** to remove three screws on the driver side and four screws on the passenger side.

B: Use a **90 degree pick tool** to remove three rivets on the driver side and two rivets on the passenger side.

C: Use a **13mm socket** to loosen the two plastic nuts on the driver side.

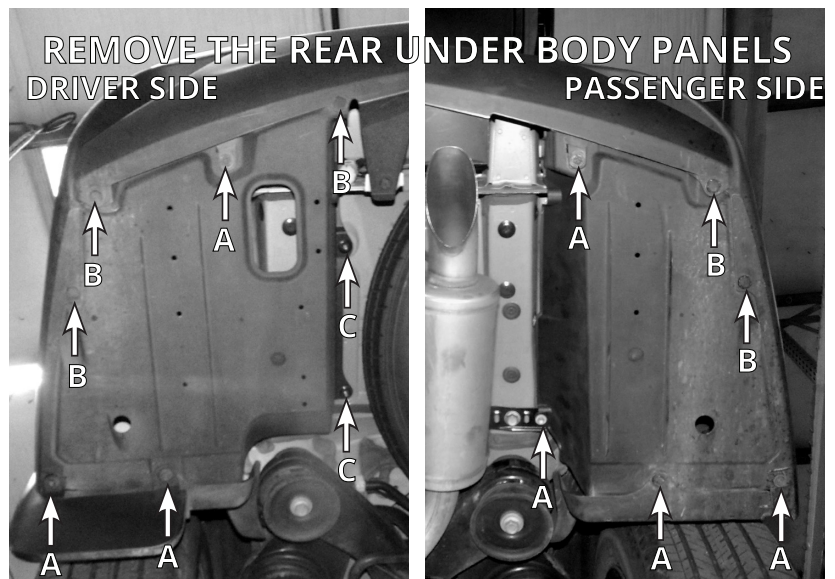

FIGURE A2: VIEW UNDER THE REAR OF THE VEHICLE



3. Locate the frame rails under the rear of the vehicle. Use a 90 degree pick tool to remove the plastic covers and grommets covering the holes in the frame rails.

A: Remove three plastic covers on the driver side and two plastic covers on the passenger side.

B: Remove two grommets on each frame rail.

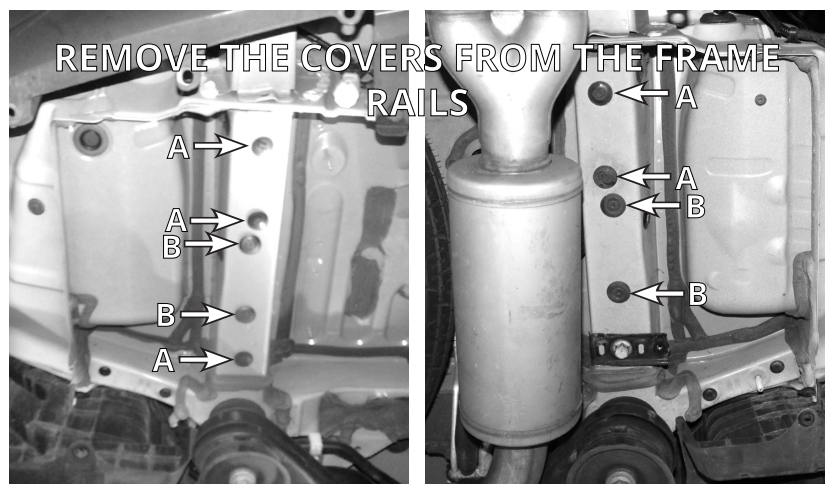

FIGURE A3: VIEW UNDER THE REAR OF THE VEHICLE

PREPARE TO INSTALL CONTINUED



3/4"
SOCKET

4. Use a 3/4" socket to remove the indicated bracket from the passenger side frame rail. Save the bracket for later reinstallation.

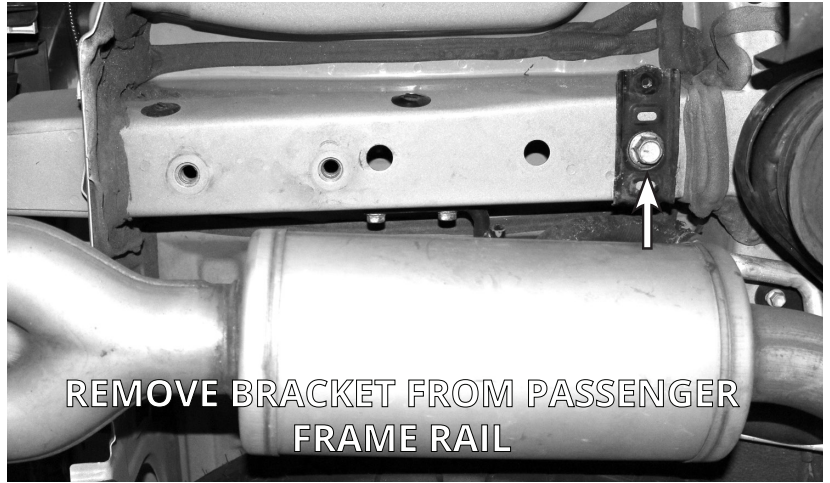

FIGURE A4: VIEW UNDER THE REAR OF THE VEHICLE



90 DEGREE
PICK

5. Use a 90 degree pick tool to remove two rivets holding plastic tabs on the fascia, see Figure A5.



FIGURE A5: VIEW UNDER THE REAR OF THE VEHICLE

INSTALL HITCH FRAME



19mm
SOCKET

6. The side plates will attach to the vehicle using six M12 x 35mm cap screws and 1/2" conical washers. The hardware will thread into the holes uncovered in Step 3. Begin by attaching the passenger side plate and the bracket removed in Step 4 to the passenger side frame rail, see Figure B1. Loosely attach bolts at this time.

NOTE: Install the conical washers so the teeth are placed against the side plate.

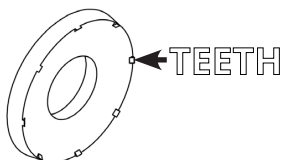

REINSTALL BRACKET FROM STEP 4 HERE

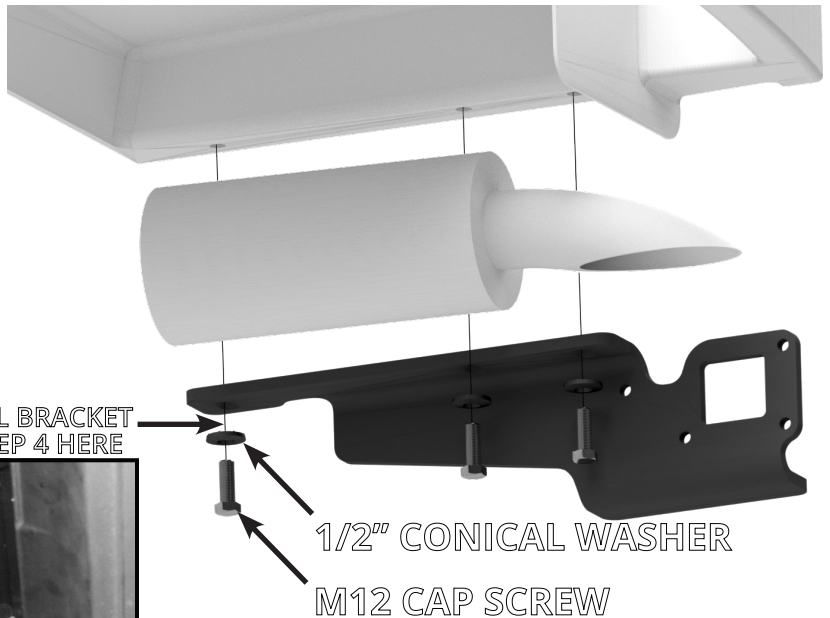

FIGURE B1: VIEW OF PASSENGER SIDE PLATE

INSTALL HITCH FRAME CONTINUED



9/16"
SOCKET

- Attach the hitch frame to the passenger side plate using four 3/8" x 1-1/4" cap screws and 3/8" flange nuts, as shown in Figure B2. Loosely attach the bolts at this time.

NOTE: The plastic tabs shown in Step 5 need to be positioned under the hitch frame when installation is complete.

LOOSELY ATTACH THE HITCH FRAME TO THE PASSENGER SIDE PLATE

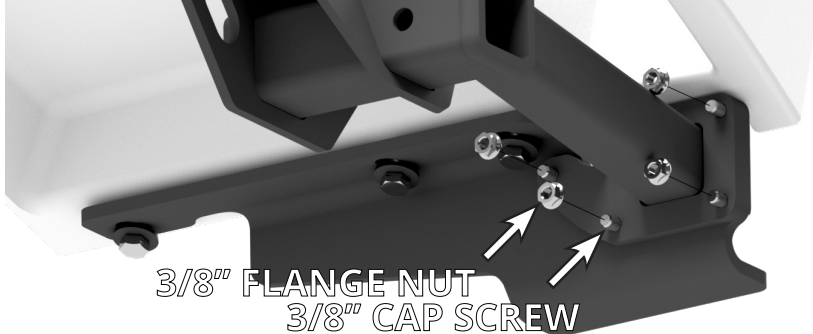

FIGURE B2: VIEW OF PASSENGER SIDE PLATE AND HITCH FRAME



19mm
SOCKET



9/16"
SOCKET

- Loosely attach the driver side plate to the hitch frame similar to Step 7. Attach the driver side plate to the vehicle, as shown in Figure B3. Hand tighten all of the hardware. Check that the hitch frame is centered in the vehicle and adjust if necessary.
- Tighten all the cap screws, Then torque the M12 cap screws to 85 ft.-lbs. Next, torque the 3/8" cap screws and nuts to 45 ft.-lbs.

LOOSELY ATTACH DRIVER SIDE PLATE TO THE HITCH FRAME AND THE FRAME RAIL

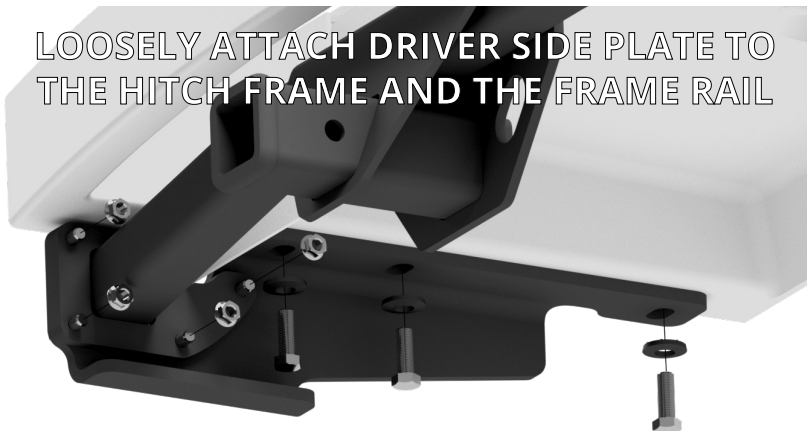

FIGURE B3: VIEW OF DRIVER SIDE PLATE



DREMEL TOOL



FILE

- Use a Dremel tool (or similar tool) and file to cut out the two sections of the driver side under body panel shown in Figure B4.

NOTE: The passenger side under body panel does not need to be trimmed.

CUT OUT SECTIONS OF THE DRIVER SIDE UNDER BODY PANEL

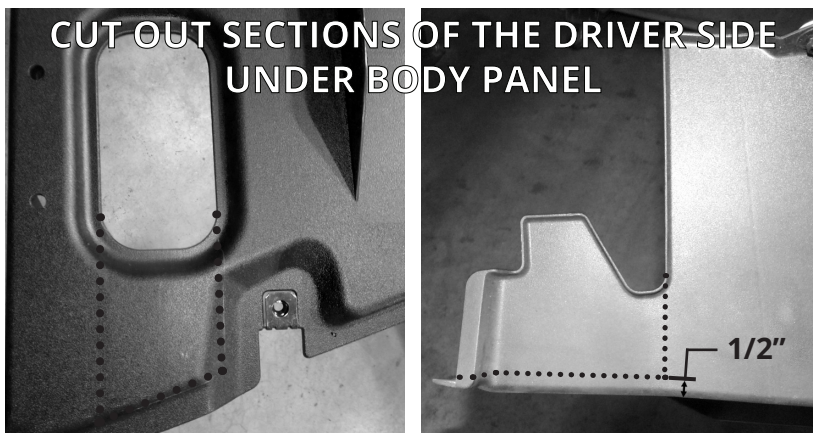

FIGURE B4: DRIVER SIDE PANEL CUT OUTS

- Reattach the rivets removed in Step 5. Replace the two under body panels removed in Step 2. Lastly, replace the spare tire to complete installation.

FINISHED INSTALLATION



FIGURE B5: VIEW OF INSTALLED HITCH UNDER REAR OF VEHICLE