

FIFTH WHEEL TO GOOSENECK ADAPTER

25,000 lb Maximum Trailer Weight
3,250 or 4,500 lb Maximum Pin Weight



CALL OR E-MAIL FOR INSTALLATION SUPPORT

PHONE: 800-248-6564

EMAIL: hitches@turnoverball.com

FIFTH WHEEL TO GOOSENECK ADAPTERS AND KITS

See www.bwtrailerhitches.com to determine which options are needed for your setup.

STANDARD ADAPTER

FITS LIPPERT® 1621, 1621HD, 1116, AND 1716 PIN BOXES

RVGN3153

25,000 lb
Maximum trailer weight
3,250 lb
Maximum pin weight



RVGN3154

25,000 lb
Maximum trailer weight
4,500 lb
Maximum pin weight

RHINO ADAPTER

FITS LIPPERT® RHINO PIN BOXES

RVGN3163

25,000 lb
Maximum trailer weight
3,250 lb
Maximum pin weight

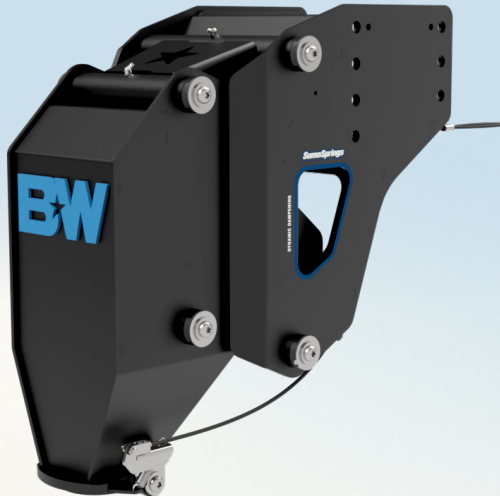

RVGN3164

25,000 lb
Maximum trailer weight
4,500 lb
Maximum pin weight

INCLUDED HARDWARE

HARDWARE BOX

#	DESCRIPTION	QTY
1	42" SAFETY CHAINS WITH HOOKS	2
2	5/8" FLANGE HEAD CAP SCREWS	10
3	5/8" FLANGE NUTS	10

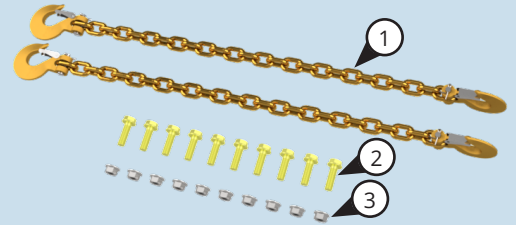

LIPPERT® 1116/1716 SHIM KIT

PART NUMBER: RVXA3140

#	DESCRIPTION	QTY
4	SHIM PLATES	2
5	5/8" FLANGE HEAD CAP SCREWS	2
6	5/8" FLANGE NUTS	2
7	3/8" X 3/4" ROLL PINS	4

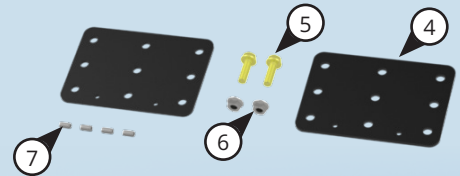

RAM HD TRUCK W/FACTORY HITCH SAFETY CHAIN KIT

PART NUMBER: RVXA3141

#	DESCRIPTION	QTY
8	51-1/2" SAFETY CHAINS WITH HOOKS	2



IMPORTANT SAFETY NOTICE FOR HITCH INSTALLERS AND CUSTOMERS.

Read all installation and operating instructions along with all labels before installing or using this product. Do not perform any installation or towing procedures without fully understanding the correct tools and actions for all steps. Call B&W Trailer Hitches Customer Service Department for support, if needed.

⚠️ WARNING Failure to comply with the safety information in these instructions could result in serious injury or death.

- ⚠️ Do not modify this product in any manner. Doing so could alter its integrity and lead to a loss of attachment between the trailer and the tow vehicle.
- ⚠️ Adding hitch components to the chassis of any vehicle or trailer can be hazardous. There is potential for electric shock, shifting or falling of unstable trailer, damage to vehicle, injury from tool usage and many other hazards. This installation must be completed by someone who is aware of the hazards involved. This person must be knowledgeable of proper safety procedures for a vehicle and trailer modification of this nature, and of usage of the equipment required to perform the installation.
- ⚠️ Before installation is performed, check for signs of damage or excessive corrosion. Do not install hitch components over vehicle or trailer parts that are broken or have compromised structural integrity.
- ⚠️ Do not exceed the tow or weight ratings of the adapter, gooseneck ball, tow vehicle, or trailer. See vehicle and trailer manufacturer information for ratings. Exceeding these ratings may cause damage to towing components or loss of attachment between the trailer and vehicle.
- ⚠️ A visual inspection of the towing components should be performed before each use. Regularly check that all connections are secure. Check for cracks or damage to the gooseneck ball, adapter, pin box mounting plates, and frame. Do not use the adapter if cracks or damage outside of normal wear is found. Using an adapter that has unsecured connections and/or cracks or damage could result in damage to the tow vehicle, trailer, towing components and loss of attachment between the tow vehicle and trailer.
- ⚠️ Follow all manufacturer instructions and warnings for tow vehicle and trailer.
- ⚠️ Without proper knowledge, towing can be a dangerous activity. Understand all the risks involved with towing before proceeding. For information on towing safety, see **"The Trailer Handbook: A Guide to Understanding Trailer and Towing Safety"** from the National Association of Trailer Manufacturers, www.NATM.com and your trailer and tow vehicle manufacturer's owner's manual.
- ⚠️ The B&W Fifth Wheel to Gooseneck Adapter is designed to be used only with a 2-5/16" ball measuring 2.283" to 2.313" in diameter.

PREPARE FOR INSTALLATION

TOOLS REQUIRED

- Impact wrench or ratchet with 15/16" socket
- 15/16" Box end wrench
- Torque wrench
- Hole alignment tool
- Eye protection
- Tape measure and marking pen
- Hammer (if installing shim kit)

⚠️ WARNING: The pin box and adapter are heavy components and may be awkward to position during installation. Use a minimum of two people or a lifting device, such as forklift, to properly support the weight of the pin box during removal and the adapter during installation. Failure to properly support the weight of the pin box and adapter may result in property damage or serious injury.

⚠️ WARNING: Be aware of pinch points while handling and installing the adapter. Keep hands free of the coupler latch handle and the gap between the front and rear sections of the adapter to prevent serious injury.

1. Prepare trailer for installation.

- Move the trailer to a flat, level area.
- Chock the trailer tires.

2. Pin box removal.

- Mark the bolt hole locations that are being used on the pin box mounting plates.
- Remove the breakaway switch and/or electrical box if attached to the factory pin box.
- Loosen but do not remove all bolts connecting the pin box to the trailer.
- Fully support the weight of the pin box, then remove the bolts and lower the pin box to the ground.

3. **Identify pin box series.** The pin box series of the trailer may be identified by a label on the RV or pin box or by contacting the RV manufacturer. If needed, measure the hole pattern on the pin box mounting plates and use the table and diagram below to determine the correct series.

LIPPERT® PIN BOX MOUNTING PLATES				
FRAME SERIES	A	B	C	WIDTH BETWEEN PLATES
Rhino	7-1/2"	2"	-	12"
1621	7-7/8"	2"	-	12"
1621HD	7-7/8"	2"	-	12"
1116	8-3/4"	2-1/2"	4-3/8"	12-1/2"
1716	8-3/4"	2-1/2"	4-3/8"	12-1/2"

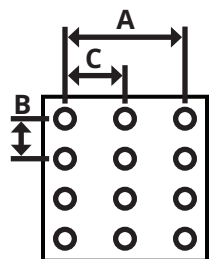

Pin box mounting plate diagram

PREPARE FOR INSTALLATION CONTINUED

4. **Mark the mounting holes.** Using the guide below, locate the pin box series for the trailer and mark the Position 1 mounting holes on the inside of the adapter. The measurements shown refer to the distance from the top of the ball to the bottom hole of the pin box mounting plates on the trailer.

RHINO ADAPTER FOR LIPPERT® RHINO PIN BOXES (2" of height adjustment). MINIMUM OF 5 BOLTS PER SIDE.

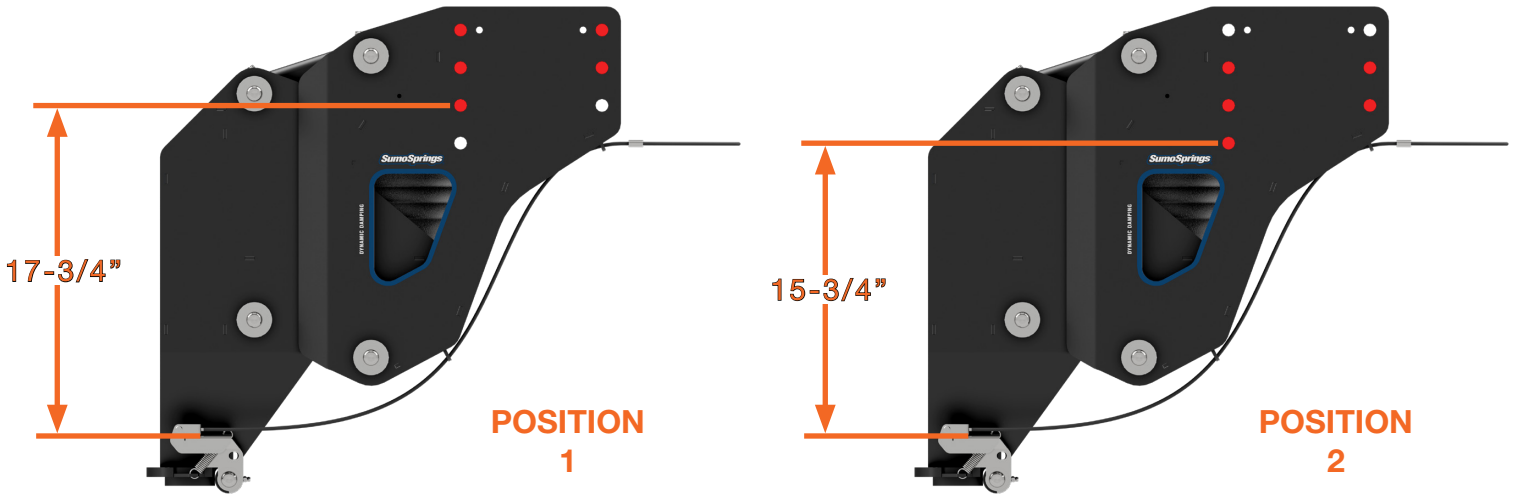

STANDARD ADAPTER FOR LIPPERT® 1621/1621HD PIN BOXES (2" of height adjustment). MINIMUM OF 5 BOLTS PER SIDE.

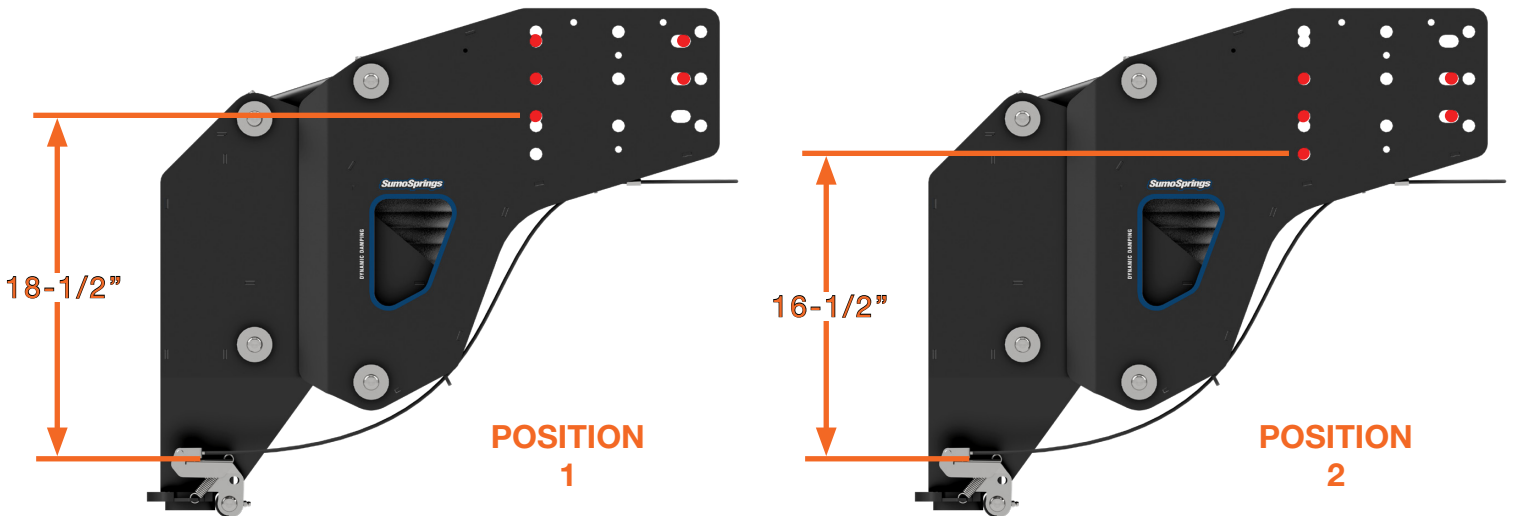

STANDARD ADAPTER FOR LIPPERT® 1116/1716 PIN BOXES (2-1/2" of height adjustment). MINIMUM OF 6 BOLTS PER SIDE.

- **REQUIRES SHIM KIT - Increases adapter width to 12-1/2".**

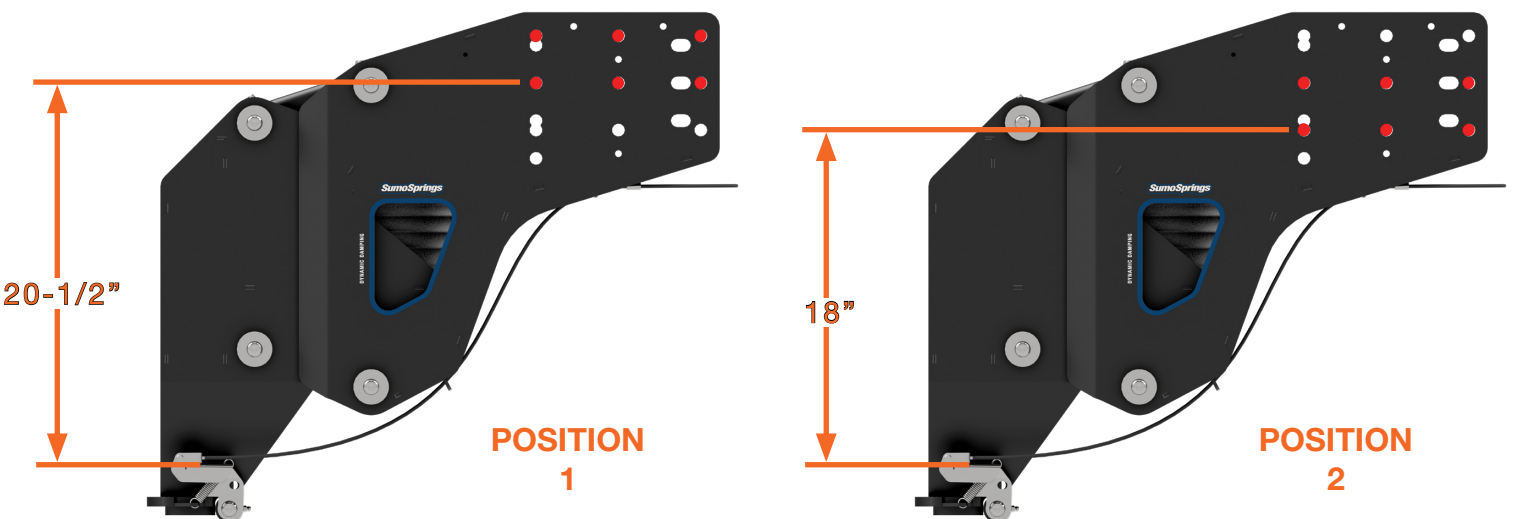

PREPARE FOR INSTALLATION CONTINUED

5. **Install shim plates.** If the space between the pin box mounting plates is 12", skip to Install Adapter onto the Trailer. If the space is 12-1/2" like the Lippert® 1116/1716 pin box series, an RVXA3140 shim kit will need to be installed. Locate the four 3/8" roll pins. Start the roll pins into the small holes of the shim plates, see **Figure A1**. Align the shim plates with the holes in the adapter, as shown in **Figure A2**. Drive the roll pins in with a hammer until the end of the pins are flush with the shim plates and the shim plates are tight against the adapter.

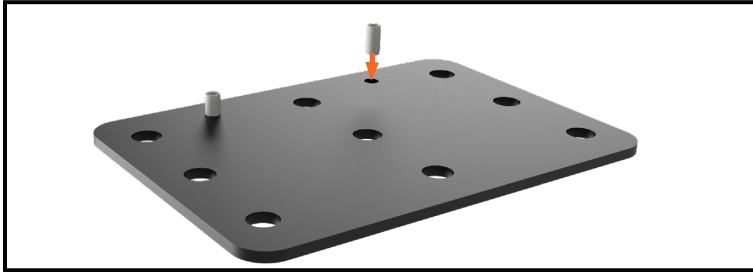

FIGURE A1: Installing roll pins into the shim plates

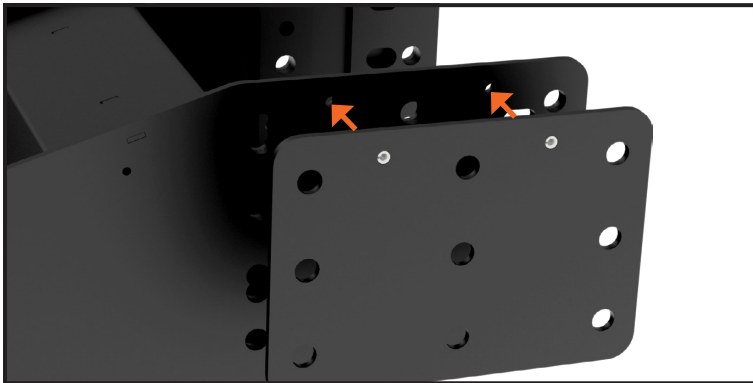

FIGURE A2: Installing shim plates onto adapter

INSTALL ADAPTER ONTO THE TRAILER

1. **Lift the adapter into place.** Use the hole alignment tool to line up the holes marked on the adapter with the holes the pin box was installed in. Fasten in place using the provided hardware, see **Figure B1**.

⚠ WARNING: Use only the hardware supplied with the adapter in the quantity specified by the **Adapter Hole Identification Guide**. Failure to use the supplied hardware in the correct quantity can lead to structural failure and trailer separation, resulting in serious injury or death.



FIGURE B1: Rear view of installed adapter

2. **Tighten the hardware.** Torque the hardware to 150 ft.-lbs.
3. **Reattach breakaway switch.** If a breakaway switch and/or electrical box were removed from the previous pin box reattach them. The breakaway switch can be reattached using the provided mounting hole, see **Figure B2**.



FIGURE B2: View of breakaway cable mounting location

NOTICE: Height Adjustment

The trailer should be level when fully loaded with a minimum of 7" of bed rail clearance, see **Figure B3**. Failure to maintain adequate clearance between the top of the truck's bed and the bottom of the trailer may result in damage to the truck bed or trailer.

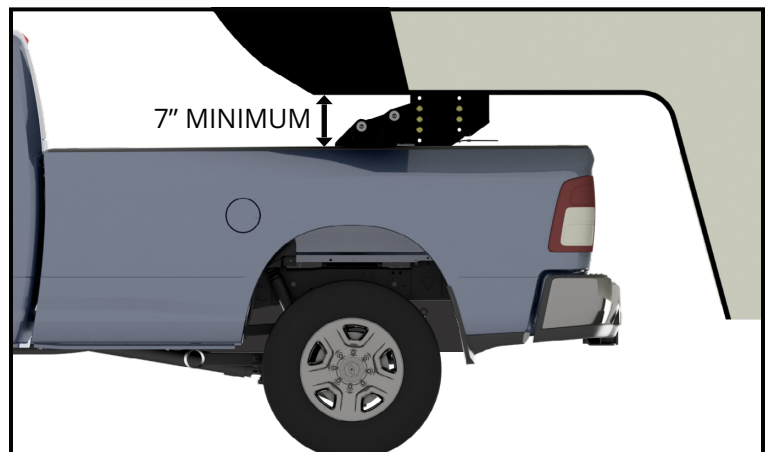

FIGURE B3: View of truck and trailer

COUPLING PROCEDURE

1. **Check latch.** Ensure the latch is in the "Couple/Tow" position before coupling, see **Figure C1**.

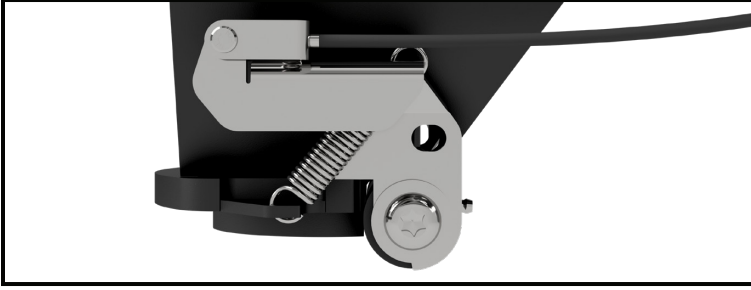

FIGURE C1: Coupler in "Couple/Tow" position

2. **Prepare tow vehicle.** Lower the truck's tailgate, install the gooseneck ball, and if needed install the safety chain anchors in the truck bed.
3. **Position tow vehicle.** Back up the truck until the gooseneck ball is directly under the coupler.
4. **Connect the trailer.** Lower the trailer until the coupler automatically couples. There will be an audible click when it is properly coupled. Confirm that the coupler is fully seated and the latch has returned to the "Couple/Tow" position.
5. **Prepare trailer connections.** Plug in the 7-way trailer connector and connect the breakaway switch cable.
6. **Attach safety chains.** Attach the supplied safety chains to the adapter and the safety chain anchors on the vehicle, see **Figure C2**.

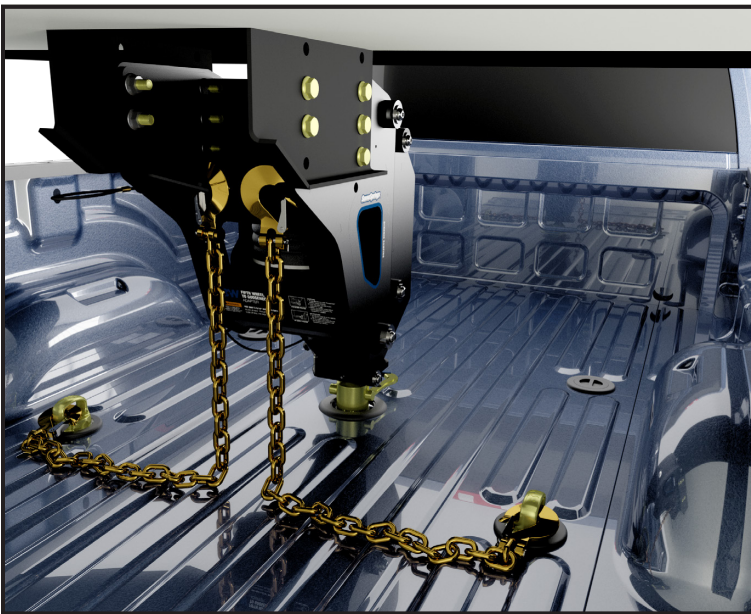

FIGURE C2: Safety Chain Attachments (RAM HD truck shown)

7. **Prep the trailer for towing.** Close the truck's tailgate. Fully retract the trailer's landing gear and un-chock the trailer tires.

TOWING SAFETY INFORMATION

WARNING: Coupler Clearance
The gooseneck ball must be free of obstructions in all directions to allow full seating of the coupler and full movement of the latching mechanism. The ball height must be at least 4" from the truck bed to the top of the gooseneck ball. Failure to follow these instructions may result in trailer separation, property damage, serious injury, or death.

WARNING: Turning Clearance
Verify that there is sufficient turning clearance between the 5th wheel trailer, truck's cab, and bumper/tailgate. An offset gooseneck ball may be needed to achieve adequate turning clearance on short bed trucks. Failure to maintain adequate turning clearance may result in property damage or serious injury.

NOTICE: Safety Chains

The factory supplied safety chains fit most applications. RAM HD trucks with the factory gooseneck to 5th wheel prep package may require longer chains (kit RVXA3141). Ensure proper length of safety chains for turning clearance before towing. Failure to use adequate length safety chains may result in damage to the attachment points.

UN-COUPLING PROCEDURE

1. **Prepare truck and trailer.** Chock the trailer tires.
2. **Disconnect trailer connections.** Lower the truck's tailgate. Disconnect the safety chains, 7-way trailer connector, and the breakaway switch cable.
3. **Open latch.** Use the pull cable to open the latch to the "Un-Couple" position, see **Figure D1**. The latch should stay open when the pull cable is released.

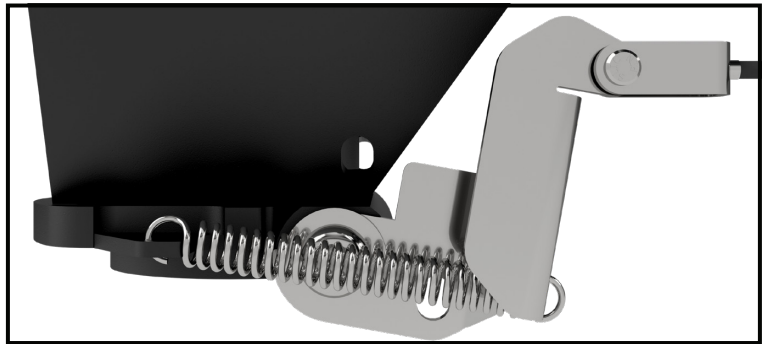

FIGURE D1: Adapter in "Un-Couple" position

4. **Disconnect the trailer.** Lower the landing gear until the coupler is completely off the gooseneck ball. Check that the latch has reset to the "Couple/Tow" position.

ROUTINE MAINTENANCE

Follow the maintenance procedures listed below before each trip and periodically as needed.

Before every trip:

- Inspect all bolted connections for loose hardware.
- Check the fifth wheel to gooseneck adapter, 2-5/16" gooseneck ball, and trailer pin box mounting plates for physical damage.
- Grease the gooseneck ball as needed.

Every 2,500 miles:

- Grease the four articulating joints through the angled grease fittings until grease purges out from the end of the joints, see **Figure E1**. Requires a flexible grease gun.

Annually:

- Grease the coupler through the straight grease fitting, see **Figure E1**. Rotate the latch handle several times to distribute the grease. Return the latch to the "Couple/Tow" position.

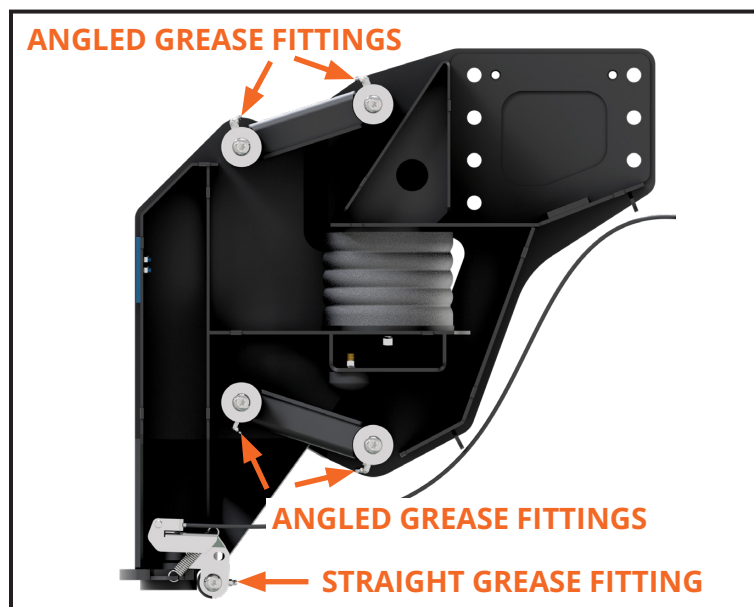
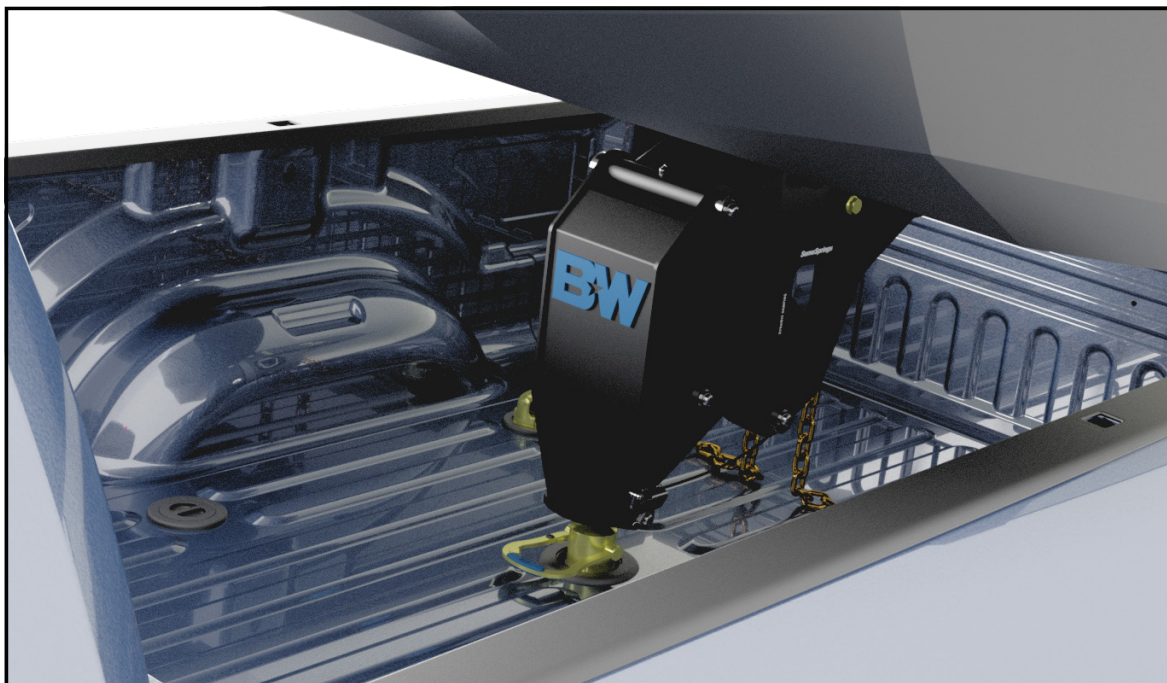

FIGURE E1: Cutaway showing the five grease fittings

<THIS INSTRUCTION MANUAL MUST BE GIVEN TO THE END USER>



AMERICAN MADE



BUILT TO LAST

SEE LIMITED LIFETIME WARRANTY AT
bwtrailerhitches.com/warranty



B&W TRAILER HITCHES
1216 HAWAII RD
P.O. BOX 186
HUMBOLDT, KS 66748

bwtrailerhitches.com