

<THESE INSTRUCTIONS MUST BE GIVEN TO THE END USER>



B&W Trailer Hitches
 1216 Hawaii Rd / PO Box 186
 Humboldt, KS 66748
 P:800.248.6564
 F:620.869.9031

Call or Email us for
 Installation Support
 hitches@turnoverball.com
 bwtrailerhitches.com

Custom 5th Wheel Hitch Mounting Rail Installation Instructions

MODEL 2405

See Limited Lifetime Warranty at
bwtrailerhitches.com/warranty

2015-2026 F150
 Except F150 Lightning, F150 Raptor & 2019-2020 F150 Limited

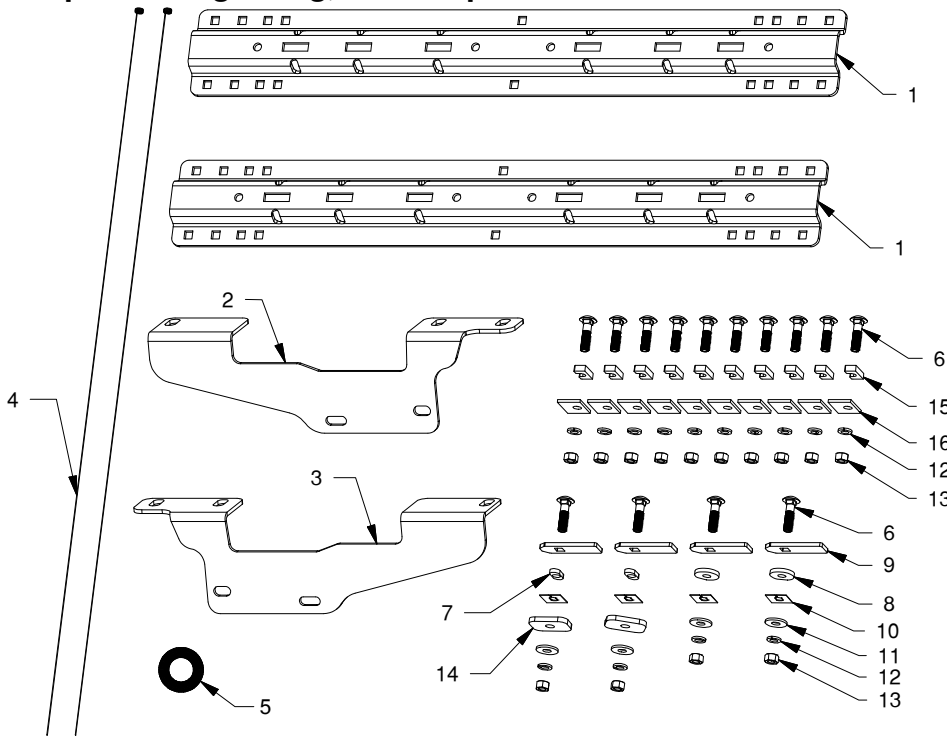

Patriot Rail Box (RVR3210)		
ITEM	DESCRIPTION	QTY
1	Mounting Rail	2

Bracket Set Box (RVR2404)		
ITEM	DESCRIPTION	QTY
2	Side Plate, Passenger	1
3	Side Plate, Driver	1
4	Fish Wire	2
5	Polypropylene Tape	1

Bracket Set Bolt Bag #1		
ITEM	DESCRIPTION	QTY
6	1/2" X 2" Carriage Bolt	14
7	Oval Frame Spacer	2
8	Circular Frame Spacer	2
9	Locking Strap	4
10	1/2" Retainer	4
11	1/2" Flat Washer	4
12	1/2" Lock Washer	14
13	1/2" Finish Nut	14
14	Rectangular Frame Spacer	2

Bracket Set Bolt Bag #2		
ITEM	DESCRIPTION	QTY
15	3/8" U-Shaped Spacer	10
16	Offset Rectangle Washer	10

⚠ WARNING Failure to comply with the safety information in these instructions could result in serious injury or death.

- ⚠** Read all installation and operating instructions along with all labels before installing or using this product.
- ⚠** Adding components to the chassis of any vehicle can be hazardous. There is potential for damage to vehicle, injury from tool usage and many other hazards. This installation must be completed by someone who is aware of the hazards involved. This person must be knowledgeable of proper safety procedures for a vehicle installation of this nature, and for usage of the equipment required to perform the installation.
- ⚠** Without proper knowledge, towing can be a dangerous activity. Understand all the risks involved with towing before proceeding. For information on towing safety, see **"The Trailer Handbook: A guide to Understanding Trailer and Towing Safety"** from the *National Association of Trailer Manufacturers*, www.NATM.com and your trailer manufacturer's owner's manual.
- ⚠** Do not exceed tow or tongue rating of coupler, tow or tongue rating of hitch, or tow or weight ratings of truck or trailer. See vehicle and trailer manufacturer information for ratings. Exceeding these ratings may cause damage to towing components or loss of attachment between the trailer and truck.
- ⚠** Additional caution must be used when towing a wedge car trailer. Towing stability greatly depends on keeping the center of gravity as low as possible. Load heavy cars over the axles. Never tow with a single car on the front of the trailer. When towing a wedge car trailer, never exceed speeds that are reasonable for the roadway conditions (e.g. turns, going around a curve, etc.). Failure to account for proper trailer center of gravity and speeds that are reasonable for the roadway conditions may cause damage to the truck, trailer, towing components, and loss of attachment between the truck and trailer.
- ⚠** Do not modify this product in any manner. Doing so could alter its integrity and lead to a loss of attachment between the trailer and the tow vehicle.
- ⚠** A visual inspection of the hitch should be performed before each time you tow. Regularly check that all pinned connections are secure, and that all bolted connections are at the correct torque specification. Check for cracks or damage to the hitch. Do not tow with the hitch if cracks or damage outside of normal wear is found. Towing with a hitch that has cracks or damage could result in damage to the tow vehicle, trailer, towing components or loss of attachment between the tow vehicle and trailer.

PREPARING TO INSTALL

NOTICE: It may be necessary to remove the spare tire, heat shield, and/or fender liners before installation.

NOTICE: If truck is equipped with a removable bed liner or mat, it should be removed or it must be cut to allow the mounting rails to connect directly with the bed. It is acceptable to install the mounting rails over a spray-in bed liner.

- Review parts and tools.** Remove all parts from the packaging and familiarize yourself with all the parts and tools required. Use the parts list on the front page to verify that all parts and hardware are present.

Installation of the mounting rails requires several common tools and a few specialized tools. Below is a listing of equipment used during a typical installation.

- Patriot 5th Wheel or Slider Base
- Impact Wrench or Ratchet with 3/4" Socket
- Drill and 1/8" & 9/16" Drill Bits
- 3/4" Box End Wrench
- Hammer
- Flashlight
- Tape Measure
- Ear Protection
- Torque Wrench
- Center Punch
- Eye Protection

- Add polypropylene tape to kit components.** As an added layer of protection between the aluminum body of the bed and the steel components of this kit, a roll of polypropylene tape is included in the mounting kit box. Apply the tape to the components that will contact the bed of the truck, as shown below.

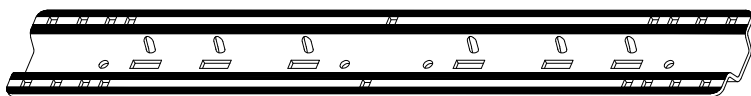

Figure A1: Polypropylene tape application.

- **Side Plates:** Apply tape to the outside edge of each flange as shown in Figure A2.

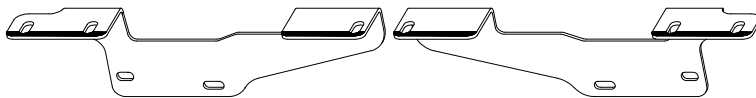

Figure A2: Polypropylene tape application.

- **3/8" U-Shaped Spacers and Offset Rectangle Washers:** Apply tape to washers as needed when they are mounted against the bed, see Figure A3.

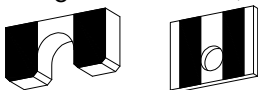

Figure A3: Polypropylene tape application.

NOTICE: Galvanic corrosion information.

B&W recommends that the installer reference Ford SVE Bulletin Q-222R1 for attaching accessories to aluminum panels and structure. It can be found at fordbbas.com/bulletins.

DRILL REAR MOUNTING HOLES

- Layout the rear mounting rail.** Place a mounting rail onto the bed of the truck. Hook a tape measure over the rear edge of the bed (not on any part of the tailgate), measure the location for the mounting rail as shown in Figure B1. Next, center the mounting rail in the bed by measuring the distance on either side from the edge of the rail to the side of wheel well. The rail will be centered when both measurements on either side of the rail are the same.

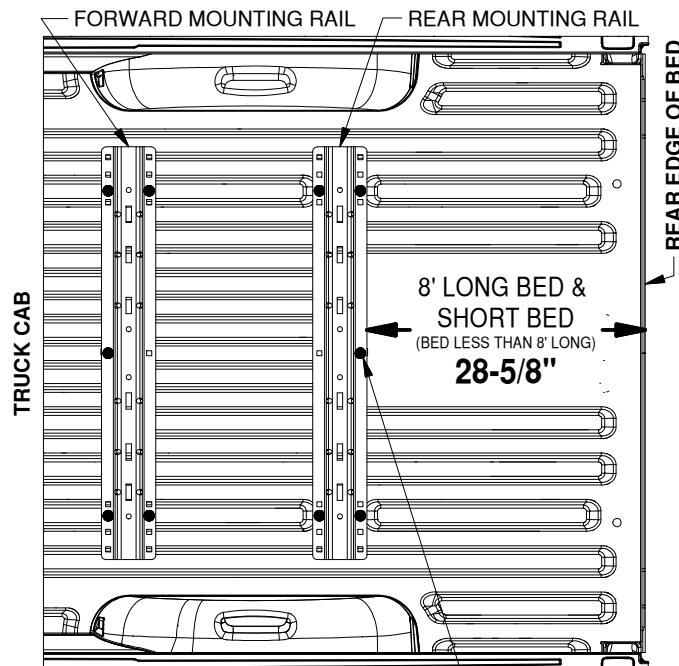

Figure B1: View over bed, showing drill locations for the forward and rear rails. DRILL LOCATIONS HIGHLIGHTED BY BLACK DOTS

IMPORTANT: If your truck has a spray-in bed liner you will need to take this into account when you are measuring, and add the thickness of the applied liner that has been sprayed over the end of the bed.

IMPORTANT: The mounting rail is designed to install only at the described location. Failure to place the mounting rail precisely may result in added difficulty during installation and/or property damage.

- Mark hole locations.** While carefully ensuring the mounting rail does not move, use a center punch tool to mark the 5 drill locations on the rear rail. See Figure B1 for hole marking locations for this installation (forward rails will install in a later step). Once all 5 rear rail locations are clearly marked, move the bed rail out of the way and drill each location with an 1/8" drill bit.

WARNING: The fuel tank of the truck may be directly below the area of the bed which needs to be drilled. Always carefully examine the area under the truck where modification will occur. Make certain that the tank, or other equipment, is not damaged during drilling. Damage to the tank may result in property damage, serious injury, or death.

INSTALL FRAME CARRIAGE BOLTS

1. **Install forward carriage bolt.** Each carriage bolt is held in the frame with a locking strap, frame spacer and 1/2" retainer. Locate the forward mounting hole shown in Figure C1. Attach the carriage bolt to the locking strap by passing the bolt through the strap. Insert the locking strap through the mounting hole, until it is completely inside the frame and only the carriage bolt is passing through the hole, see Figure C2. Install a circular frame spacer onto the bolt, see Figure C3. To prevent the bolt from falling into the frame, thread a retainer onto bolt until it is snug.

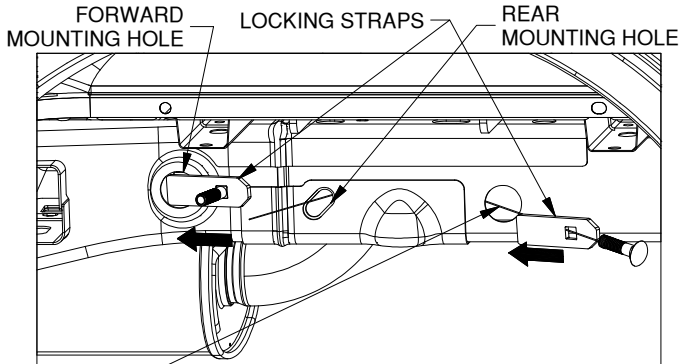

FISH WIRE — **Figure C1:** View of driver side wheel well.

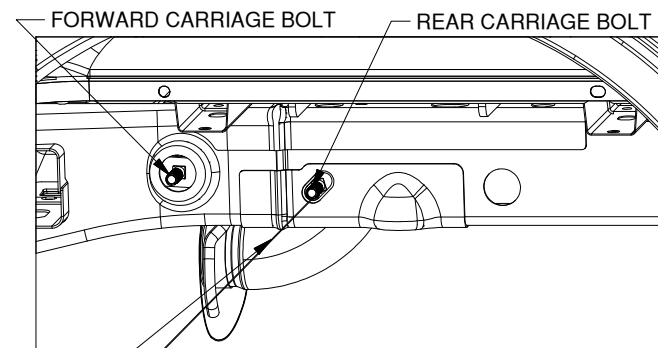

FISH WIRE — **Figure C2:** View of driver side wheel well.

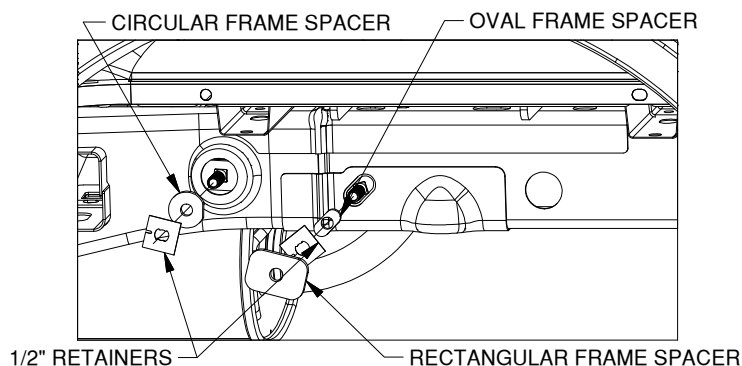

Figure C3: View of driver side wheel well.

2. **Install rear carriage bolt.** Locate the rear mounting hole shown in Figure C1. Use a fish wire to thread the rear carriage bolt and locking strap into the mounting hole, see Figures C1 & C2. Install an oval frame spacer onto the carriage bolt, see Figure C3. Thread a retainer onto the bolt until it is snug against the frame. Place a rectangular frame spacer on the rear carriage bolt. Repeat Steps 1 & 2 on the other side of the truck.

ENLARGE HOLES & INSTALL SIDE PLATES

1. **Check hole locations.** Align each side plate to the side of the frame where the side plate will be installed, see Figure D1. Check that the 1/8" holes are centered within the slots in the side plate flanges, see Figure D2. If the 1/8" drilled holes are not centered re-drill the 1/8" holes until the side plates and the drilled holes are aligned.

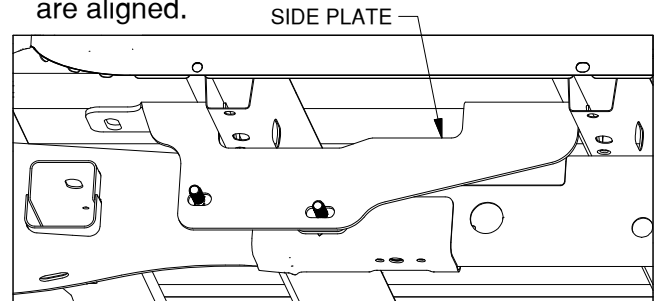

Figure D1: View of driver side wheel well.

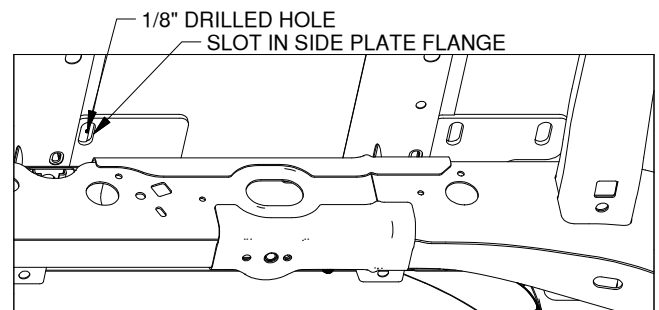

Figure D2: View inside the driver side frame.

2. **Enlarge the holes.** On top of the bed, using the 1/8" holes as pilots, drill out each hole with a 9/16" bit.
3. **Install side plates.** Each side plate (driver and passenger side) will install over the carriage bolts previously placed into the frame. Slowly guide the side plate over the carriage bolts. Attach each plate (driver side shown below) with two 1/2" washers, 1/2" lock washers, and 1/2" finish nuts. See Figure D3. Do not fully tighten at this time. (Hardware should be hand tightened.)

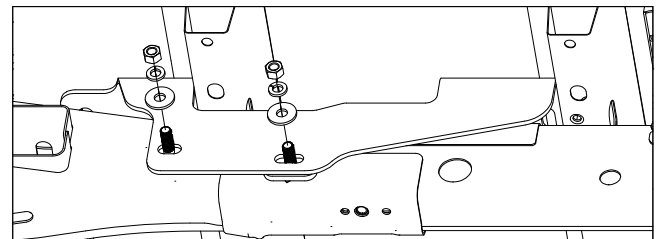

Figure D3: View of driver side wheel well.

NOTE: Access to the area above the fuel tank is limited. Placing the U-shaped spacers below the bed during the "Install Forward Mounting Rail" section can be difficult. It may be easier to place the spacers while installing the side plate. Strategies such as using tape to secure the spacers under the holes in the bed or over the slots in the side plate may be helpful.

INSTALL REAR MOUNTING RAIL

NOTICE: Due to the corrugation in the truck bed, 3/8" U-shaped spacers are provided to function as space fillers between the mounting rails and the bed. Always place a 3/8" U-shaped spacer in the gap either above the bed (between the mounting rail and the bed) or below the bed (between the bed and the side plates). Failure to use U-shaped spacers will result in property damage when hardware is tightened.

1. **Install the rear mounting rail.** Re-position the rear mounting rail over the drilled 9/16" holes in the bed. Place 3/8" U-shaped spacers where needed between the bed and the mounting rail. Next, place a 1/2" x 2" carriage bolt through the mounting rail and into each of the five drilled locations, see Figure E1. Under the bed place 3/8" U-shaped spacers where needed between the bed and the side plate flanges. Attach each of the carriage bolts with an offset rectangle washer, lock washer, and nut. Hand tighten each nut.

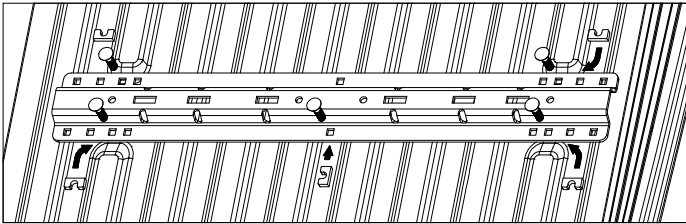

Figure E1: View of truck bed from the tailgate.

INSTALL FORWARD MOUNTING RAIL

1. **Position the forward mounting rail.** For this step the base which will be used in the mounting rails is required. Place a mounting rail into the truck bed in front of the rear mounting rail. Place the base over the rail attachment points and carefully lower it until the pin tabs pass through the attachment points on the rear mounting rail. Attach the forward mounting rail to the forward mounting points on the base, see Figure F1. The base should rest flat against the top of the rails. With the base still attached, ensure that the forward rail is centered in the truck bed.

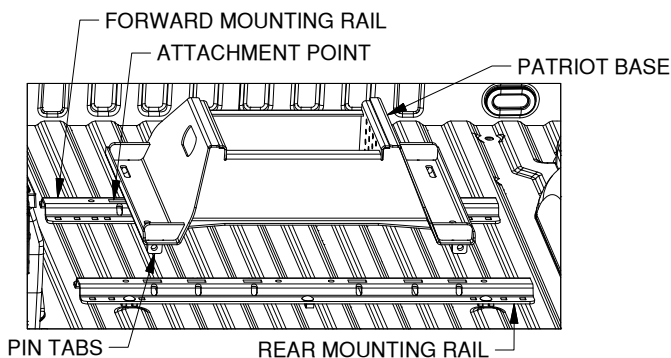

Figure F1: View of truck bed from the tailgate.

IMPORTANT: Before drilling forward mounting holes pull the RV base towards the rear of the truck and push the forward rail towards the cab of the truck to correctly space the mounting rails, see Figure F2.

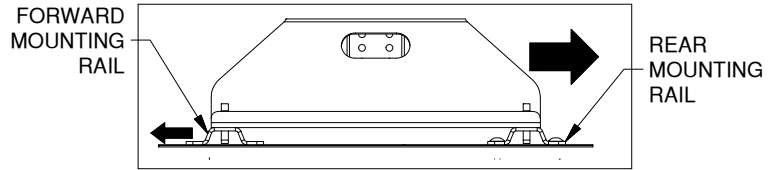

Figure F2: Side view of RV base and mounting rails.

- WARNING:** Before drilling forward mounting holes carefully examine the area under the truck where modification will occur.
2. **Drill forward mounting holes.** Using the same methods as used for the rear mounting rail mark, drill, check, and enlarge the holes for the forward mounting rail. Refer to "ENLARGE HOLES & INSTALL SIDE PLATES" section, Steps 1 through 2, on previous page. Notice that the hole locations are slightly different than the rear rail, see Figure B1 (on the second page).
3. **Install forward mounting rail.** Re-position the forward mounting rail over the drilled 9/16" holes in the bed. Place 3/8" U-shaped spacers where needed between the bed and the mounting rail. Install a 1/2" x 2" carriage bolt through the mounting rail into each of the five drilled holes, as shown in Figure F3. Under the bed place 3/8" U-shaped spacers where needed between the bed and the side plate flanges. Attach each of the carriage bolts with an offset rectangle washer, lock washer, and nut. Hand tighten each nut.

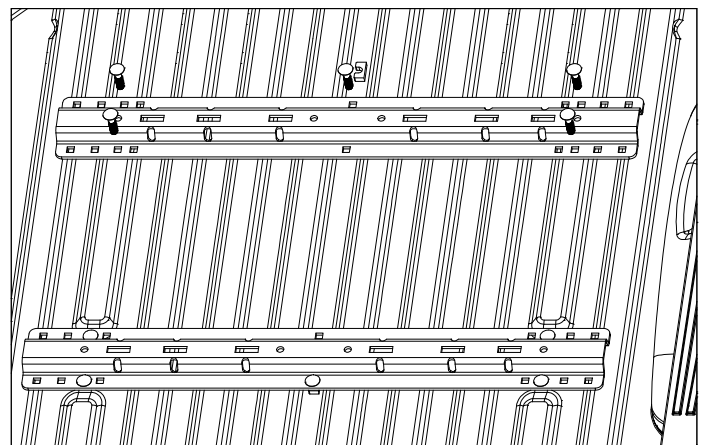

Figure F3: View of truck bed from the tailgate.

4. **Tighten hardware.** Using a torque wrench, first torque all the 1/2" nuts in the mounting rails to 80 ft-lbs. Second torque all 1/2" nuts in the side plates to 80 ft-lbs.
5. **Replace truck components.** Replace the spare tire, heat shield, fender liners and/or any other truck components that were removed during installation at this time.