

<THESE INSTRUCTIONS MUST BE GIVEN TO THE END USER>



B&W Trailer Hitches
 1216 Hawaii Rd / PO Box 186
 Humboldt, KS 66748
 P:800.248.6564
 F:620.869.9031

Call or Email us for
 Installation Support
 hitches@turnoverball.com
 www.bwtrailerhitches.com

See Limited Lifetime Warranty at
turnoverball.com/warranty

Installation Instructions

PUCP7502

PUCP7502BA

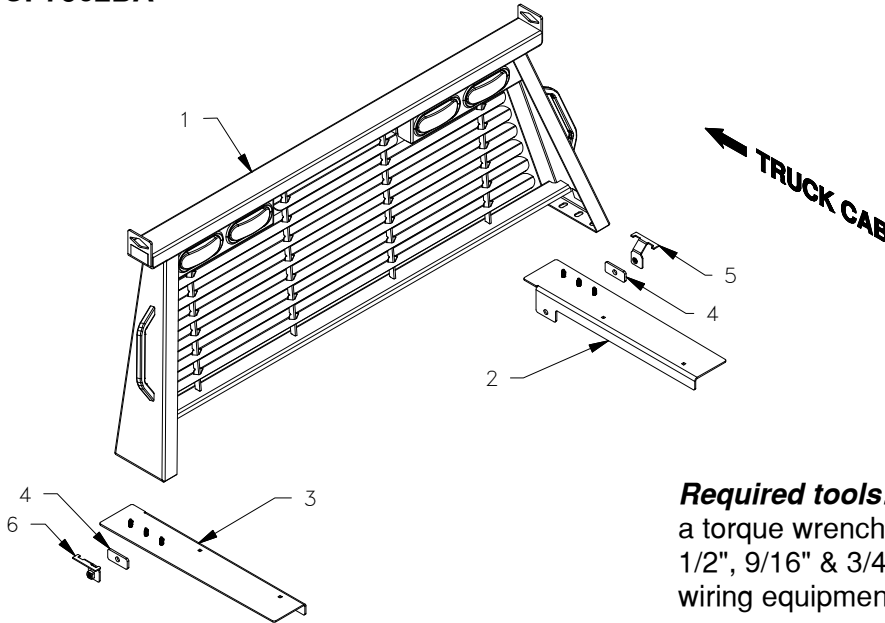

CAB PROTECTOR PARTS LIST		
ITEM	DESCRIPTION	QTY
1	Cab Protector	1
2	Passenger Side Bed Protector	1
3	Driver Side Bed Protector	1

HARDWARE KIT		
ITEM	DESCRIPTION	QTY
4	Mounting Bracket Spacer	2
5	Passenger Side Mounting Bracket	1
6	Driver Side Mounting Bracket	1
	5/16" X 1-1/2" Carriage Bolts	4
	5/16" Flat Washers	4
	5/16" Lock Washers	4
	5/16" Finish Nuts	4
	3/8" Large Flat Washers	6
	3/8" Lock Washers	6
	3/8" Finish Nuts	6
	1/2" X 1-1/2" Cap Screws	2
	1/2" Lock Washers	2

Required tools: Installation of the Cab Protector requires a torque wrench capable of measuring 18, 20 & 80 ft-lbs, 1/2", 9/16" & 3/4" Sockets, a 5/16" Drill bit and Drill, and wiring equipment.

⚠️ WARNING

Failure to comply with the safety information in these instructions could result in serious injury or death.

- ⚠️ Read all installation and operating instructions along with all labels before using this product.
- ⚠️ Do not modify this product in any manner. Doing so could alter its integrity and lead to a loss of attachment between the Cab Protector and truck.
- ⚠️ This installation must be completed by someone who is aware of the hazards involved. This person must be knowledgeable of proper safety procedures for a vehicle modification of this nature, and for usage of the equipment required to perform the installation.

PREPARE FOR INSTALLATION

- Verify proper fit of Cab Protector.** Place the bed protectors on the pickup sides as shown in Figure A1. Make sure the bed protector flange is pushed tightly against the front of the bed and the inside of the bed sides. Measure across the truck from the center of the middle threaded stud on the driver side to the center of the middle stud on the passenger side. Next, measure the distance between the two middle mounting slots on each side of the cab protector. The two measurements should be within 1/2" of each other.

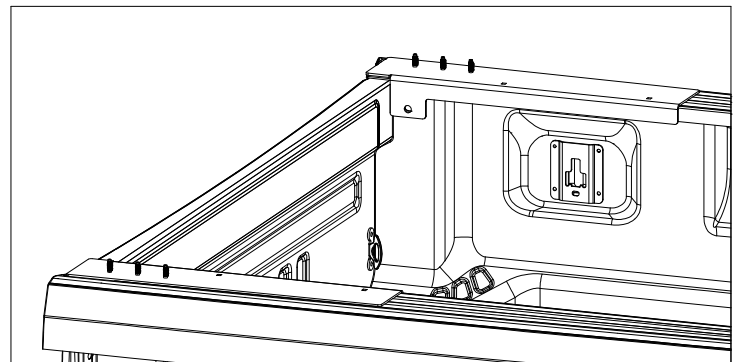
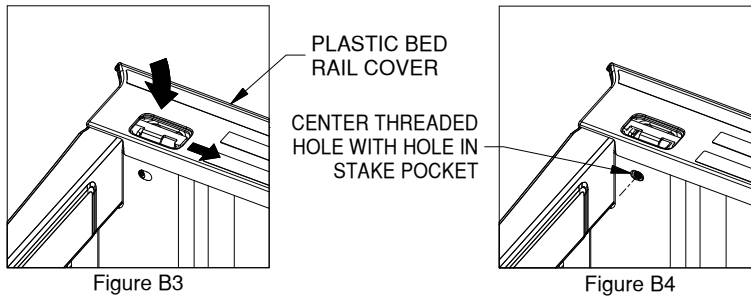
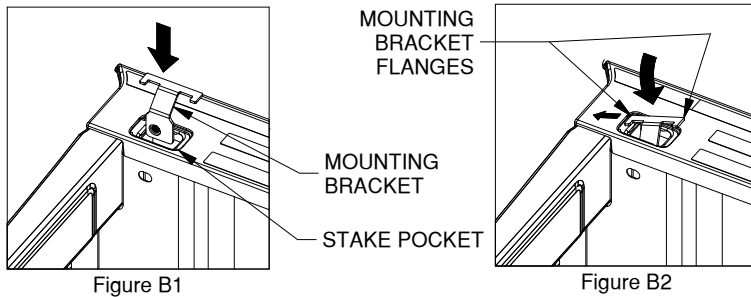

Figure A1: View looking at front of bed.

INSTALL BED PROTECTORS

NOTE: If your truck does not have a forward stake pocket hole in the plastic bed cover you will need to "pull up" the plastic bed cover to gain access to the stake pocket. Replace the cover after the mounting bracket is installed

1. **Install mounting brackets.** Locate the driver and passenger side mounting brackets. Each bracket will be installed in the stake pocket with the threaded hole offset toward the cab, see Figure B1. The flanges of the brackets will be under the plastic bed rail covers. Start by inserting the bracket into the stake pocket, then, angle the top of the bracket so one flange slips under the edge of the plastic bed cover, see Figure B2. Push the bracket under the plastic until the flange on the other side of the bracket is past the edge of the stake pocket. Push the bracket down so that both bracket flanges are against the metal body of the truck. Pull the bracket so that the flange on the other side of the bracket is under the plastic, see Figure B3. Align the threaded hole in the bracket with the hole in the stake pocket until centered, see Figure B4.



2. **Install 1/2" hardware:** Place the bed protectors back on the bed sides, as shown in Figure A1. Locate the 1/2" cap screw, 1/2" lock washer and 1/4" thick spacer block. Place the spacer block between the flange of the bed protector and the outside of the stake pocket. With the lock washer on the 1/2" cap screw, pass the cap screw through the hole in the flange of the bed protector and spacer block, see Figure B5. Thread the cap screw into the mounting bracket installed earlier. Once the cap screw is most of the way in, push the bed protector towards the cab, then tighten the 1/2" cap screw to 80 ft-lbs.

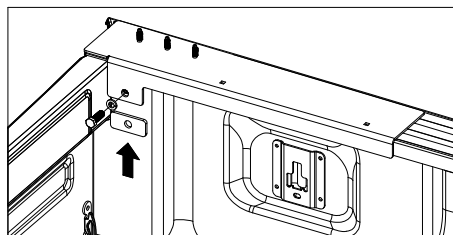

Figure B5

3. **Drill the hole locations.** Check under the bed rail in the area of each of the square holes in the bed protectors. Make sure there are no lights, wires or other obstructions. Push each bed protector against the inside of the truck bed sides. Using the square holes as a pilot, drill through the truck bed sides using a 5/16" Drill bit.

NOTICE: Galvanic corrosion information.

B&W recommends that the installer references Ford SVE Bulletin Q-222R1 for attaching accessories to aluminum panels and structure. It can be found at fordbbas.com/bulletins.

4. **Install the carriage bolts.** Insert a 5/16" X 1-1/2" Carriage Bolt in each of the drilled holes and secure using a flat washer, lock washer and finish nut, see Figure B6. Tighten each nut to 18 ft-lbs.

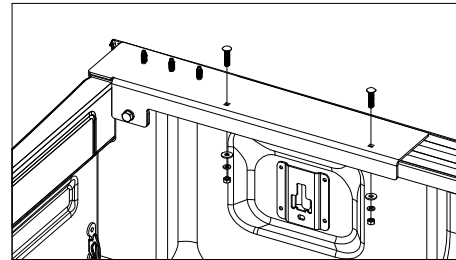

Figure B6.

INSTALL CAB PROTECTOR

WARNING: Components of the Cab Protector are heavy and cumbersome to handle. Failure to use proper lifting techniques and an adequate amount of people when moving and handling the Cab Protector could result in property damage or serious injury.

1. **Mount Cab Protector.** Position the slots on the bottom of the cab protector over threaded studs on the bed protectors, see Figure C1. Fasten the cab protector with the provided 3/8" Large flat washers, lock washers, and finish nuts. Before fully tightening, make sure the cab protector is centered with the truck as viewed from the rear. Then tighten the 6 nuts on the cab protector to 20 ft-lbs. Do not overtighten.

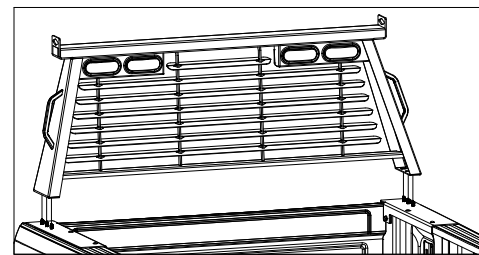

Figure C1: View looking at back of truck.

2. **Install Wiring.** Splice the tail of the cab protector wiring harness into the vehicle's wiring. The Green wire is for the passenger side turning signal and braking. The Yellow wire is for the driver side turning signal and braking. The Brown wire is for clearance. The White wire is for ground. Remove excess wire so that there is not any loose wiring. Be sure that wiring is protected from sharp edges or other obstacles that could damage the wires. When installed correctly the two outside lights will function as stop, turn, and tail lights while the inside two lights will only function as tail lights.