

<THESE INSTRUCTIONS MUST BE GIVEN TO THE END USER>



B&W Trailer Hitches
 1216 Hawaii Rd / PO Box 186
 Humboldt, KS 66748
 P: 620.473.3664
 F: 620.869.9031

Call or Email us for
 Installation Support
 hitches@turnoverball.com
 bwtrailerhitches.com

Custom 5th Wheel Hitch Mounting Rail Installation Instructions

MODEL 2604

See Limited Lifetime Warranty at
bwtrailerhitches.com/warranty

2019 RAM 1500 Model DT Gas Engine Trucks

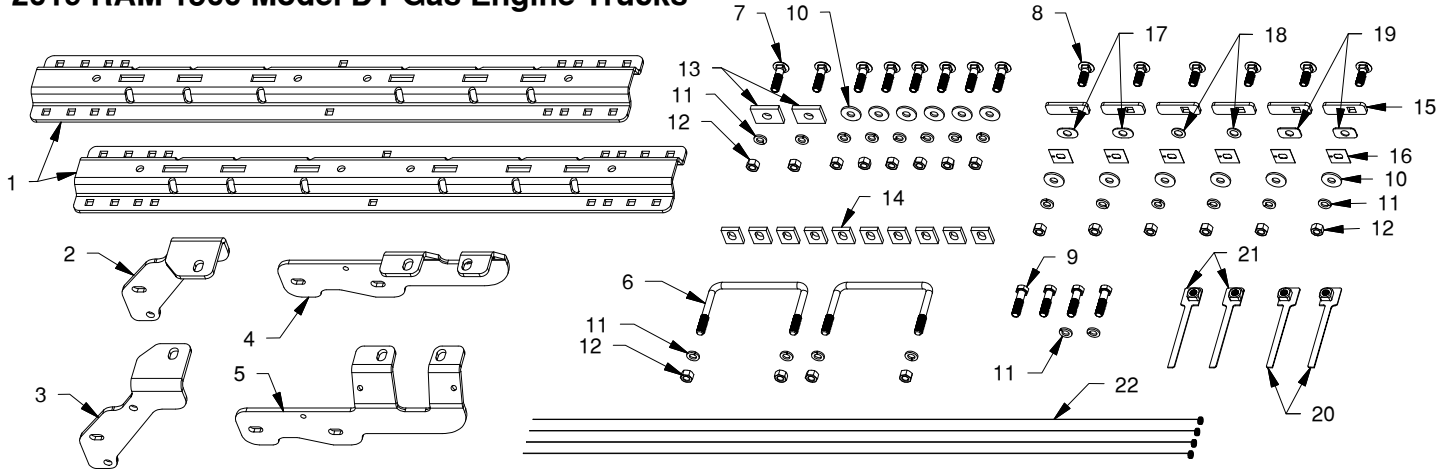

PARTS LIST			PARTS LIST			PARTS LIST		
ITEM	QTY	DESCRIPTION	ITEM	QTY	DESCRIPTION	ITEM	QTY	DESCRIPTION
1	2	Mounting Rail (Separate Box)	8	6	1/2" X 1-1/2" Carriage Bolt	16	6	Bolt Retainer
2	1	Driver Side Front Side Plate	9	4	1/2" X 2" Cap Screw	17	2	Oval Frame Spacer
3	1	Passenger Side Front Side Plate	10	12	1/2" Flat Washer	18	2	Circle Frame Spacer
4	1	Driver Side Rear Side Plate	11	20	1/2" Split Lock washer	19	2	Rectangle Frame Spacer
5	1	Passenger Side Rear Side Plate	12	18	1/2" Finish Nut	20	2	Passenger Side Nut Guide
6	2	1/2" X 6-1/4" X 4" U-Bolt	13	2	2" X 1-1/2" X 5/16" Spacer	21	2	Driver Side Nut Guide
7	8	1/2" X 2" Carriage Bolt	14	10	5/16" Thick Offset Spacer	22	4	Fish Wire
			15	6	Locking Strap			

⚠️ WARNING

Failure to comply with the safety information in these instructions could result in serious injury or death.

- ⚠️ Read all installation and operating instructions along with all labels before using this product.
- ⚠️ Adding components to the chassis of any vehicle can be hazardous. There is potential for damage to vehicle, injury from tool usage and many other hazards. This installation must be completed by someone who is aware of the hazards involved. This person must be knowledgeable of proper safety procedures for a vehicle installation of this nature, and for usage of the equipment required to perform the installation.
- ⚠️ Without proper knowledge, towing can be a dangerous activity. Understand all the risks involved with towing before proceeding. For information on towing safety, see **"The Trailer Handbook: A guide to Understanding Trailer and Towing Safety"** from the *National Association of Trailer Manufacturers*, www.NATM.com and your trailer manufacturer's owner's manual.
- ⚠️ Do not exceed tow or tongue rating of coupler, tow or tongue rating of hitch, or tow or weight ratings of truck or trailer. See vehicle and trailer manufacturer information for ratings. Exceeding these ratings may cause damage to towing components or loss of attachment between the trailer and truck.
- ⚠️ Additional caution must be used when towing a wedge car trailer. Towing stability greatly depends on keeping the center of gravity as low as possible. Load heavy cars over the axles. Never tow with a single car on the front of the trailer. When towing a wedge car trailer, never exceed speeds that are reasonable for the roadway conditions (e.g. turns, going around a curve, etc.). Failure to account for proper trailer center of gravity and speeds that are reasonable for the roadway conditions may cause damage to the truck, trailer, towing components, and loss of attachment between the truck and trailer.
- ⚠️ Do not modify this product in any manner. Doing so could alter its integrity and lead to a loss of attachment between the trailer and the tow vehicle.
- ⚠️ Regularly check that all bolted connections are at the correct torque specification. A visual inspection should be performed before each time you tow.

PREPARING TO INSTALL

NOTICE: Some steps of this Patriot rail kit assembly will require two people.

NOTICE: It may be necessary to remove the spare tire and/or heat shield before installation.

NOTICE: If truck is equipped with a removable bed liner or mat, it should be removed or it must be cut to allow the mounting rails to connect directly with the bed. It is acceptable to install the mounting rails over a spray in bed liner.

NOTE: Remove all parts from the packaging and familiarize yourself with all the parts and tools required. Use the parts list on the front page to verify that all parts and hardware are present.

⚠ Do not install side plates or U-bolts over wiring or brake lines. Always place the hitch components directly against the frame of the truck. Failure to move such components can lead to property damage or serious injury.

Installation of the mounting rails requires several common tools and a few specialized tools. Below is a listing of equipment used during a typical installation.

- Impact wrench or ratchet with a 3/4" socket
- 3/4" box end wrench
- Drill and 1/8", 9/16" Drill bits
- Patriot 5th wheel or Slider Base
- Hammer
- Flashlight
- Tape Measure
- Eye Protection
- Ear Protection
- Torque Wrench
- Center Punch Tool

DRILL REAR MOUNTING HOLES

1. **Layout the rear mounting rail.** Place a mounting rail onto the bed of the truck. Hook a tape measure over the rear edge of the bed (not on any part of the tailgate), measure the location for the mounting rail as shown in Figure A1. Next, center the mounting rail in the bed by measuring the distance on either side from the edge of the rail to the sides of the bed. The rail will be centered when both measurements on either side of the rail are the same.

IMPORTANT: If your truck has a spray-in bed liner you will need to take this into account when you are measuring, and add the thickness of the applied liner that has been sprayed over the end of the bed.

IMPORTANT: The mounting rail is designed to install only at the described location. Failure to place the mounting rail precisely may result in added difficulty during installation and/or property damage.

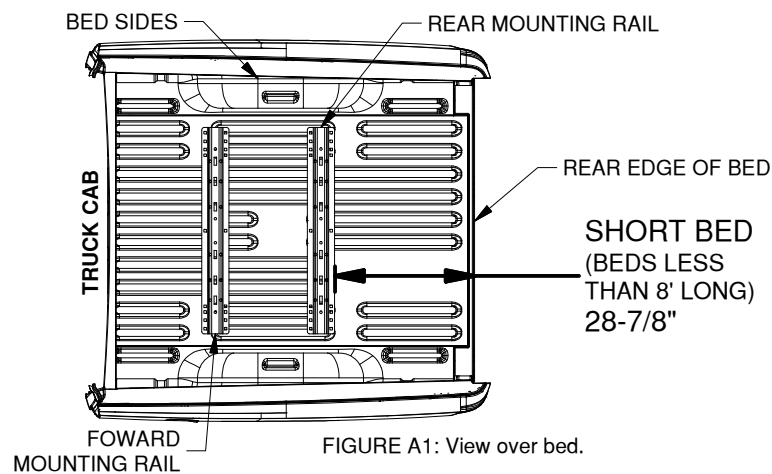

FIGURE A1: View over bed.

NOTICE: The hole pattern used in the rear rail will be different depending on your suspension. Study Figure A2 carefully prior to marking your hole locations.

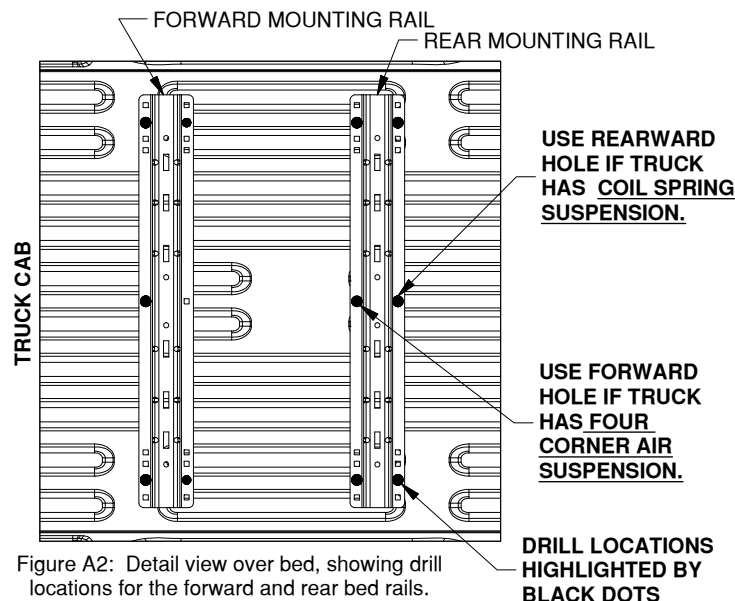

Figure A2: Detail view over bed, showing drill locations for the forward and rear bed rails.

2. **Mark the hole locations.** While carefully ensuring the mounting rail does not move, use a center punch tool to mark the five drill locations on the rear rail that match your truck's suspension style, shown in Figure A2. (Forward rails will install on a later step.) It is critical that the five drill locations be marked exactly in the center of the square hole in the rail. Once all five rear rail locations are clearly marked, move the bed rail out of the way and drill each location with an 1/8" drill.

⚠ Truck components such as the fuel tank, air tanks, tubing, and wiring may be directly below the area of the bed which needs to be drilled. Always carefully examine the area under the truck where modification will occur. Make certain that no truck components are damaged during drilling. Damage to these components, such as the fuel tank, may result in property damage, serious injury or death.

INSTALL REAR MOUNTING HARDWARE

- 1. Prepare for hardware installation.** Start by locating four 1/2" x 1-1/2" carriage bolts, four locking straps, two circle frame spacers, two oval frame spacers, four bolt retainers, and four fish wires. Identify the 1" round hole, the 1" x 1-1/2" slot on the outside of the frame and the 1-3/8" hole on the bottom of the frame behind the axle where the hardware will mount, see Figure B1.

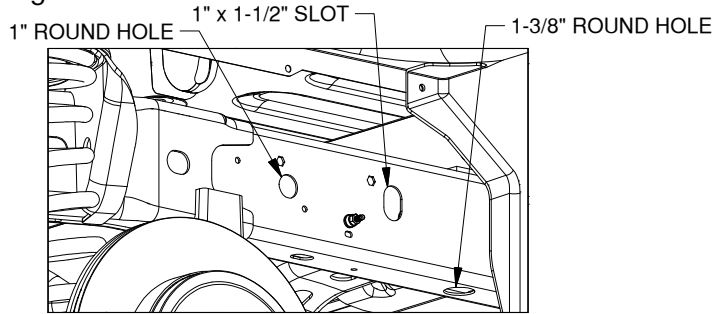

Figure B1: View looking into driver side wheel well.

- 2. Thread fish wire through frame.** Insert the coil end of the fish wire into the 1" round hole and fish it through the frame towards the rear of the truck and out the larger hole in the bottom of the frame. Pass the locking strap onto the fish wire and attach the coil end of the fish wire to the carriage bolt. To keep the hardware from getting hung up inside the frame, the locking strap and the bolt need to go through the frame separated, not with the bolt through the square hole in the strap, see Figure B2.

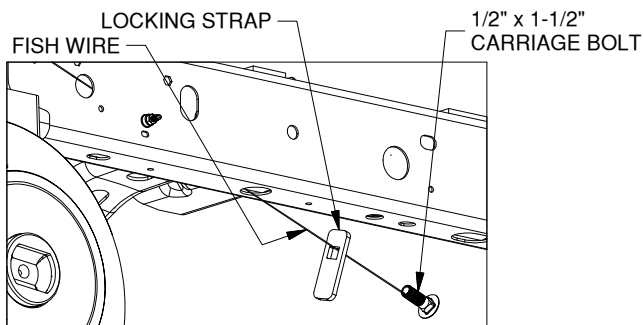

Figure B2: View looking at driver side frame under bed.

- 3. Pull fish wire through frame.** With the fish wire through the locking strap, push the locking strap completely into the frame. Next, pull the carriage bolt into the frame. Continue pulling on the fish wire until the threaded portion of the bolt is sticking out of the frame. Push the circle frame spacer over the carriage bolt and into the hole in the frame. The spacer will locate the bolt within the center of the hole. While keeping the bolt from falling into the frame, remove the fish wire from the end of the bolt. Thread the bolt retainer onto the bolt and tighten until it is flush with the outside of the frame. The spacer must be inside the frame hole and not stick past the face of the frame, see Figure B3.

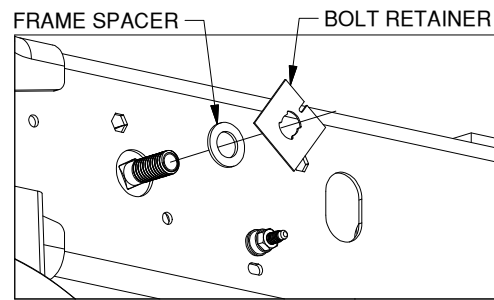

Figure B3: View looking at driver side frame.

- 4. Repeat for the rest of the holes.** Using the method in Steps 2 and 3 install the three remaining bolts into the frame. Refer to Figure B1 for hole and slot locations.
- 5. Install the rear side plates.** Locate the two rear side plates, four 1/2" flat washers, lock washers, and nuts. The rear side plates will install so that the two flanges on the top of the side plate will be on either side of the bed cross member directly behind the axle. Loosen or detach wiring connections as needed so the side plate can pass under the wiring. The grounding nut and connector will also need to be temporarily removed until side plate is secured. Pass the flanges over the frame and around the cross member while guiding the rear side plate holes over the carriage bolts, as shown in Figure B4. Attach the rear side plates with 1/2" flat washers, lock washers and nuts and hand tighten. Re-secure wiring components.

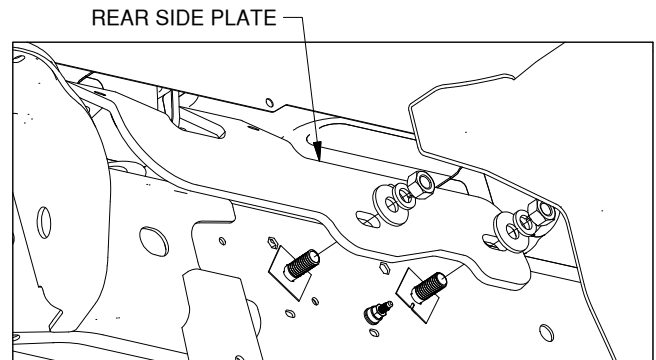

Figure B4: View looking at driver side frame.

DRILL REAR MOUNTING RAIL HOLE LOCATIONS

1. **Check the hole locations.** Make sure the rear side plates are flat against the frame and that the two flanges on top are flat against the bottom of the bed. The 1/8" pilot holes need to be aligned front to back in the center of the slots in the two rear side plate flanges, as shown in Figure C1. If the 1/8" drill holes can't be centered within the slots, re-drill the 1/8" holes until the side plates and the drilled holes can be aligned.

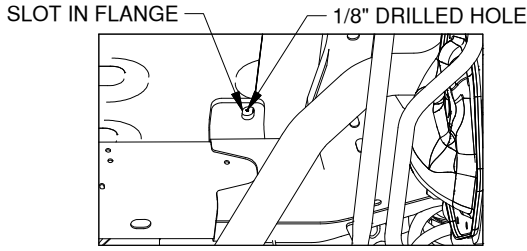

Figure C1: View looking up under the truck at the inside of the driver side frame.

2. **Enlarge the holes.** On top of the bed, using the 1/8" holes as pilots, drill out each hole with a 9/16" bit.

INSTALL REAR MOUNTING RAIL

NOTICE: Due to the corrugation of the truck bed, 5/16" thick offset spacers are provided to function as space fillers between the mounting rails and the bed. Always place a spacer in the gap above the bed (between the mounting rail and the bed). Failure to use spacers will result in property damage when hardware is tightened.

1. **Note:** If your truck has a conventional spring suspension continue to Step 2. If your truck has a four corner air suspension skip to Step 3.

2. The rear mounting rail (spring suspension).

Re-position the rear mounting rail over the drilled 9/16" holes in the bed. Place a 5/16" thick offset spacer between the bed and the mounting rail at the five drilled positions. Next, place a 1/2" x 2" carriage bolt through the mounting rail and into each of the five drilled locations, see Figure D1. Under the bed attach each of the carriage bolts with a flat washer, lock washer, and nut. The center carriage bolt will need a 2" x 1-1/2" x 5/16" spacer instead of the flat washer, see Figure D2. Hand tighten each nut.

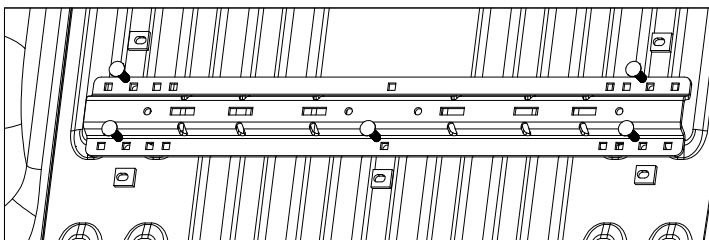

Figure D1: View looking down into the truck bed from rear of truck.

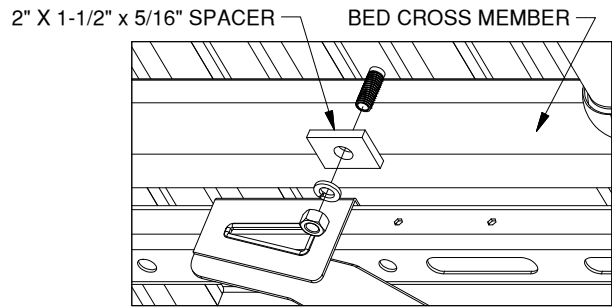

Figure D2: View looking up under the truck bed.

3. The rear mounting rail (four corner air suspension).

Re-position the rear mounting rail over the drilled 9/16" holes in the bed. Place a 5/16" thick offset spacer between the bed and the mounting rail at the five drilled positions. Due to the air tanks under the bed there is not convenient access to the underside of the two outside rearward holes in the rear mounting rail. A 1/2" x 2" cap screw and nut guide (driver and passenger) will need to be utilized. The nut guide will need to be positioned under the 9/16" hole on each side by holding the handle behind the rear side plate with the nut side down, see Figure D3. The 1/2" x 2" cap screw with a 1/2" lock washer will then need to be threaded into the nut guide from the top of the bed by another person. Next, place a 1/2" x 2" carriage bolt through the three remaining drilled locations, see Figure D4. Attach each of the carriage bolts with a flat washer, lock washer, and nut. The center carriage bolt will need a 2" x 1-1/2" x 5/16" spacer instead of the flat washer, see Figure D5. Hand tighten each nut and cap screw.

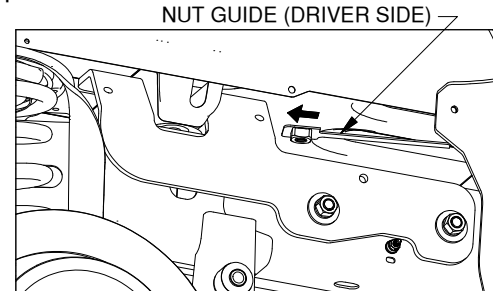

Figure D3: View looking into driver side wheel well.

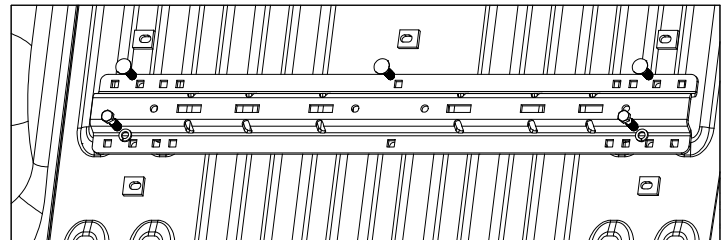

Figure D4: View looking down into the truck bed from rear of truck.

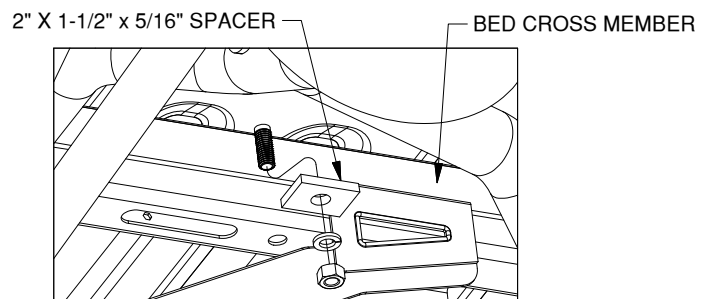

Figure D5: View looking up under the truck bed.

DRILL THE FORWARD MOUNTING RAIL HOLE LOCATIONS

1. **Position the forward mounting rail.** For this step the base which will be used in the mounting rails is required. Place a mounting rail into the truck bed in front of the rear mounting rail. Place the base over the rail attachment points and carefully lower it until the pin tabs pass through the attachment points on the rear mounting rail. Attach the forward mounting rail to the forward mounting points on the base. The base should rest flat against the top of the rails, see Figure E1. With the base still attached ensure that the forward rail is centered in the truck bed.

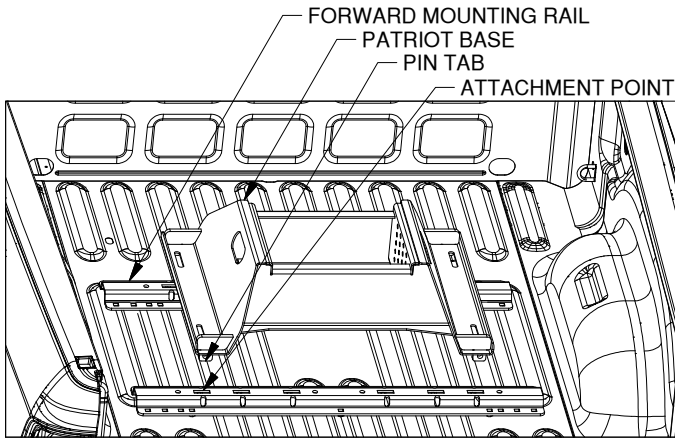

FIGURE E1: View into truck bed looking towards tailgate.

IMPORTANT: Before drilling forward mounting holes pull the RV base towards the rear of the truck and push the forward rail towards the cab of the truck to correctly space the mounting rails, see Figure E2.

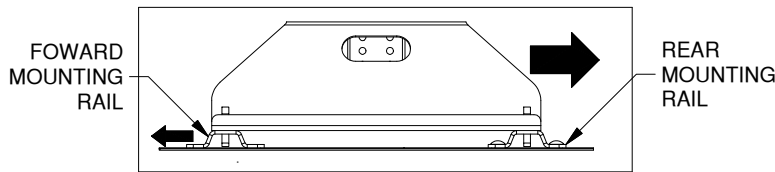

Figure E2: Side view of RV base and mounting rails.

2. **Drill forward mounting pilot holes.** Using the holes in the forward mounting rail, mark the five drill locations. Refer to "DRILL REAR MOUNTING HOLES" section, Step 2, on Page 2. Notice that the hole locations may be slightly different than the rear rail, see Figure A2. It is critical that the five drill locations be marked exactly in the center of the square hole in the forward rail. Drill each of the marked locations with a 1/8" pilot hole.
3. **Enlarge the holes.** Remove the base and move the forward rail out of the way. Use the 1/8" holes as pilots, and drill out each hole with a 9/16" bit. Drill through the bed only, it is not necessary to drill through both the bed and the bed cross member.

INSTALL FORWARD MOUNTING HARDWARE

1. **Prepare for hardware installation.** Each front side plate will install by mounting 1/2" carriage bolts into existing holes in the frame. Start by locating two 1/2" x 1-1/2" carriage bolts, two locking straps, the two rectangle frame spacers, and two bolt retainers. Identify the rectangle hole on the outside of the frame just in front of the axle where the hardware will mount, see Figure F1.

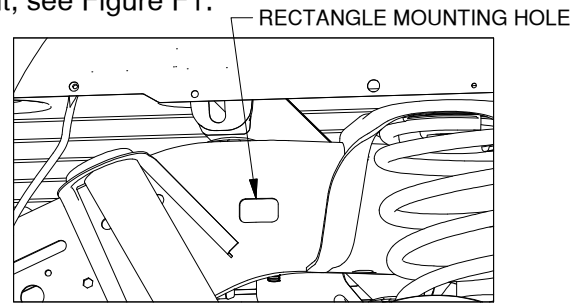

FIGURE F1: View looking into driver side wheel well.

2. **Install the carriage bolt into the frame.** First pass a locking strap over a 1/2" carriage bolt, then pass a rectangle frame spacer over the same bolt, see Figure F2. While holding onto the threaded portion of the carriage bolt, pass the locking strap completely into the frame through the rectangle hole, see Figure F3. Push the rectangle frame spacer into the hole in the frame. Thread a bolt retainer onto the bolt and tighten until it is flush with the outside of the frame, see Figure F4. The spacer must be inside the frame hole and not stick past the face of the frame. Complete this step on both sides of the frame.

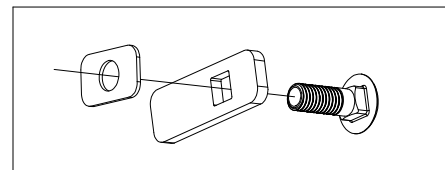

FIGURE F2: Carriage bolt assembly.

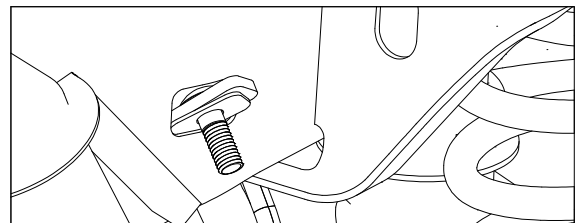

FIGURE F3: View looking into driver side wheel well.

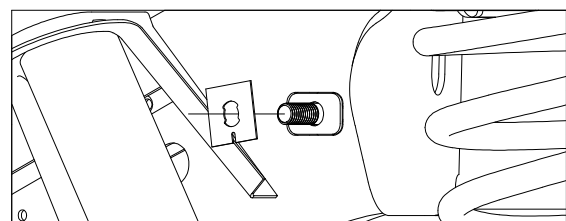

FIGURE F4: View looking into driver side wheel well.

3. Install the front side plates. Locate the 1/2" U-bolt. On the driver side of the frame, near the rectangle hole where the carriage bolt is installed, pass the U-bolt up in between the fuel tank and the frame so that the threaded ends of the U-bolt are towards the rear of the truck. Make sure there are no brake lines, wiring, or tubing between the U-bolt and the frame. When the leg of the U-bolt is past the top of the frame rotate the legs of the U-bolt towards the outside of the frame, as shown in Figure F5. Locate the driver side front side plate. Orient the side plate so the flange is up and towards the truck. Angle the flange between the frame and the bed. Align the side plate so that the U-bolt and the 1/2" carriage bolt in the frame pass through the holes in the side plate. Attach the side plate to the frame with 1/2" flat washers, lock washers, and nuts, as shown in Figure F6. Align the side plate so the slot in the flange is centered front to back in the 9/16" hole in the bed. While pushing the side plate up against the bottom of the truck bed, hand tighten the three nuts. Repeat steps for the passenger side of the frame.

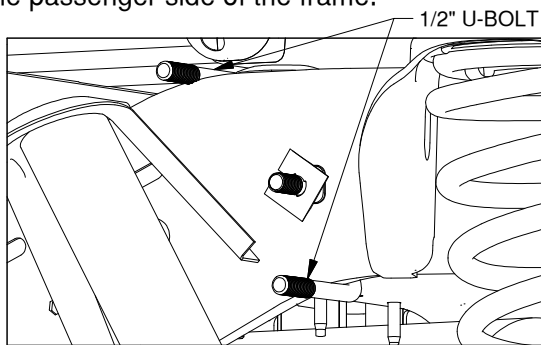

FIGURE F5: View looking into driver side wheel well.

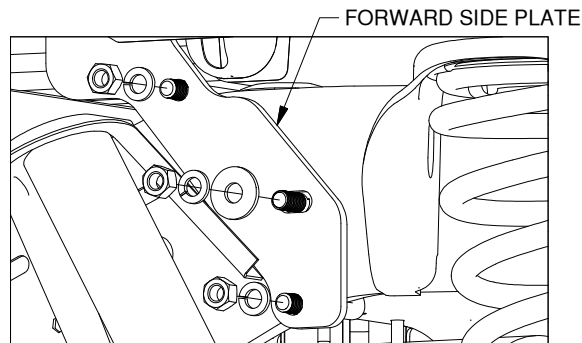

FIGURE F6: View looking into driver side wheel well.

INSTALL FORWARD MOUNTING RAIL

1. The forward mounting rail. Re-position the forward mounting rail over the drilled 9/16" holes in the bed. Place a 5/16" thick offset spacer between the bed and the mounting rail at the five drilled positions. The two outside rear bolt locations are not accessible under the bed due to the bed cross member. A 1/2" x 2" cap screw and nut guide will need to be utilized. Prepare the nut guides by putting a 60° bend in the handle about 3-3/4" from the top, see Figure G1.

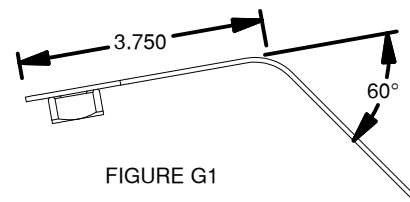

FIGURE G1

The forward mounting rail, continued. The nut guides will need to be positioned under the 9/16" hole by passing the nut on the nut guide through the vertical slot on the end of the bed cross member and turning it so the nut is on the bottom of the guide, see Figure G2. Hold the nut under the 9/16" hole while a 1/2" x 2" cap screw with a 1/2" lock washer is passed down through the forward mounting rail from the top of the bed and threaded into the nut guide by another person. Place a 1/2" x 2" carriage bolt through the three remaining drilled locations, see Figure G3. Attach each of the carriage bolts with a flat washer, lock washer, and nut. The center carriage bolt will need a 2" x 1-1/2" x 5/16" spacer instead of the flat washer. Hand tighten each nut and cap screw.

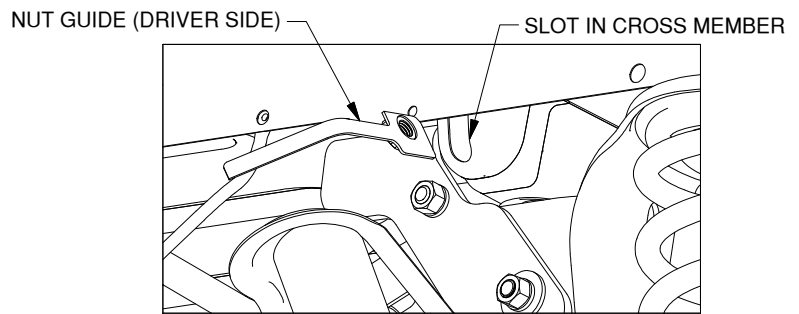

Figure G2: View looking into driver side wheel well.

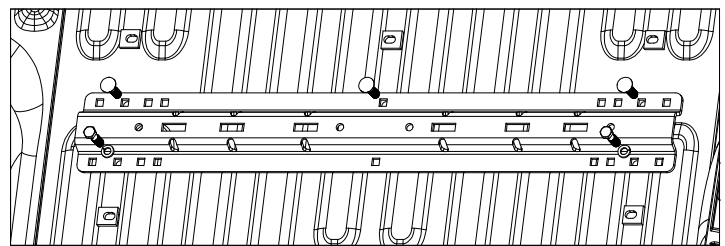

Figure G3: View looking down into the truck bed.

- 2. Tighten hardware.** Using a torque wrench, first torque all the 1/2" nuts and cap screws in the mounting rails to 80 ft. lbs. Second, torque all the 1/2" nuts in the side plates to 80 ft. lbs.
- 3. Secure frame elements.** If any wiring was moved or detached during installation, re-secure it to the frame or side plates at this time. Reinstall the heat shield and spare tire if they were removed during installation.